

FIRE

4100U-S1 Fire Indicator Panel Programming Guide



**Australian
Programming
Guide**

**LT0400
Iss 1.0**

Simplex

AMENDMENT LOG

1.0 28 November 2006 Original Issue

TABLE OF CONTENTS

<u>AMENDMENT LOG</u>	iii
<hr/>	
1 INTRODUCTION	1-1
<hr/>	
1.1 ABOUT THIS MANUAL	1-2
2 SYSTEM OVERVIEW	2-1
<hr/>	
2.1 GENERAL DESCRIPTION	2-2
3 ABOUT THE PROGRAMMING TOOLS	3-1
<hr/>	
3.1 GENERAL	3-2
3.2 4100U PROGRAMMER	3-2
3.3 4100U-S1 CONFIGURATION TEMPLATE	3-2
3.4 4100U PROGRAMMER INSTALLATION & LAUNCH	3-2
3.5 STEPS TO CONFIGURING A NEW SYSTEM	3-3
3.6 UPGRADING AN EXISTING CONFIGURATION	3-3
4 CREATING A CONFIGURATION	4-1
<hr/>	
4.1 CREATING A NEW PROJECT FILE	4-2
4.2 ADDING PANEL INFORMATION	4-2
4.3 ADJUSTING THE NUMBER OF ZONE DISPLAYS	4-3
4.4 ADDING THE AZF LOGIC	4-3
4.5 WHERE TO NEXT?	4-3
5 ADDING ADDRESSABLE DEVICES	5-1
<hr/>	
5.1 GENERAL	5-2
5.2 ADDING DEVICES TO AN SPS ADDRESSABLE LOOP	5-2
5.3 ASSIGNING DEVICES TO ZONES	5-4
6 ADDRESSABLE DEVICE SETTINGS	6-1
<hr/>	
6.1 INTRODUCTION	6-2
6.1.1 ALARM DEVICE TYPES	6-2
6.2 ADDRESSABLE DETECTOR SETTINGS	6-2
6.2.1 4098-9714E PHOTO DETECTOR	6-2
6.2.2 4098-9717E ION DETECTOR	6-2
6.2.3 4098-9733E HEAT DETECTOR	6-2
6.2.4 4098-9754E MULTISENSOR PHOTO HEAT DETECTOR	6-3

6.3 ADDRESSABLE DEVICE SETTINGS	6-4
6.3.1 4099-9032 MCP	6-4
6.3.2 4090-9001 SUPERVISED INPUT IAM OR 4090-9051 ENCAPSULATED INPUT IAM	6-4
6.3.3 4090-9002 RELAY IAM	6-4
6.3.4 4090-9101 MONITOR ZAM	6-4
6.3.5 4190-9050 4-20MA ANALOG MONITOR ZAM	6-5
6.3.6 4090-9118 RELAY IAM WITH T-SENSE INPUT	6-5
6.3.7 4090-9119 RELAY IAM WITH UNSUPERVISED INPUT	6-6
6.3.8 4090-9120AU 6 POINT I/O MODULE (4 INPUTS, 2 RELAY OUTPUTS)	6-6
6.3.9 4090-9116 ADDRESSABLE IDNET ISOLATOR	6-7
6.3.10 4090-9117AU ADDRESSABLE IDNET POWER ISOLATOR	6-7
<u>7 ADDING ZONE DISPLAYS</u>	<u>7-1</u>
7.1 GENERAL	7-2
7.2 ZONE CONTROL & LED MODULES	7-2
7.3 HARDWARE CONFIGURATION MODIFICATION	7-2
7.4 MODIFY THE CUSTOM CONTROL EQUATIONS FOR THE ZONES	7-6
<u>8 ADDING EXPANSION MODULES</u>	<u>8-1</u>
8.1 GENERAL	8-2
8.2 ADDING 4100-3101 IDNET LOOP CARD	8-2
8.3 ADDING 4100-4321 LEGACY SIGNAL CARD	8-5
8.4 ADDING LEGACY CARD – 4100-0113 RS-232/2120 INTERFACE MODULE	8-7
<u>9 CUSTOM CONTROLS</u>	<u>9-1</u>
9.1 GENERAL	9-2
9.2 CUSTOM CONTROL SYNTAX	9-2
9.3 CREATING A NEW EQUATION	9-5
9.3.1 SELECT USER PROGRAM	9-5
9.3.2 ADD INPUT STATEMENTS	9-6
9.3.3 ADD OUTPUT STATEMENTS	9-7
<u>10 AS1668 FAN CONTROLS</u>	<u>10-1</u>
10.1 TYPICAL ARRANGEMENT FOR AS1668 FAN CONTROL	10-2
10.2 AS1668 FAN CONTROL FLOWS	10-3
10.3 AS1668 FAN CONTROL STATE TABLE	10-5
10.4 AS1668 FAN CONTROL CARD PROGRAMMING	10-6
10.4.1 SWITCH CONFIGURATION	10-6
10.4.2 LED CONFIGURATION	10-7
10.4.3 POINT EDITING	10-8
10.5 AS1668 CUSTOM CONTROL EQUATIONS	10-8
10.6 AS1668 CUSTOM CONTROL EQUATIONS	10-9
10.6.1 [EQUATION] 1 TOGGLE FAN -> TOGGLE RED & GREEN LEDES	10-9
10.6.2 [EQUATION] 2 TRIGGER FAN ON	10-9
10.6.3 [EQUATION] 3 TRIGGER FAN OFF	10-10
10.6.4 [EQUATION] 4 FAN 1 TRIGGERED BUT NO AIRFLOW -> FAULT	10-10
10.6.5 [EQUATION] 5 FAN 1 STOPPED BUT AIRFLOW RUNS -> FAULT	10-11
10.6.6 [EQUATION] 6 FAN 1 FAULT REPORT ON	10-11

11	<u>BUILDING & DOWNLOADING THE CONFIGURATION</u>	11-1
11.1	GENERAL	11-2
11.2	STARTING THE TRANSFER UTILITY	11-3
11.3	SERIAL COMMUNICATION PARAMETER SETTINGS	11-3
11.4	DIRECT CONNECTION TO THE PANEL	11-4
11.5	DOWNLOADING THE CFG FILE	11-4
12	<u>APPENDICES</u>	12-1
12.1	APPENDIX A – AS4428.1 OPERATION	12-2
12.2	APPENDIX B - COMMON VARIABLES AND CUSTOM CONTROL	12-3
12.2.1	DIGITAL POINTS	12-3
12.2.2	ANALOG POINTS	12-4
12.2.3	LISTS	12-4
12.2.4	PHYSICAL HARDWARE POINTS (LEDS RELAYS ETC)	12-4
12.2.5	BATTERY TEST	12-4
12.2.6	ALARM VERIFICATION TIMING AND START UP SETTINGS	12-5
12.2.7	BRIGADE RELAY EQUATIONS	12-6
12.3	APPENDIX C - CUSTOM CONTROL FOR CONTROL KEYS AND INDICATORS	12-7
12.3.1	COMMON ZONE ALARM LED	12-8
12.3.2	ALARM / FAULT / NORMAL TEST BUTTON & LEDES	12-9
12.3.3	EXAMPLE ALARM & FAULT TEST EQUATIONS	12-11
12.3.4	A/C RESET BUTTON & A/C TRIP LED	12-11
12.3.5	BELLS ISOLATE LED & BUTTON	12-12
12.3.6	WARNING SYSTEM ISOLATE	12-13
12.3.7	CLEAN UP EQUATIONS	12-13
12.4	APPENDIX D - CUSTOM CONTROL FOR ALARM ZONE FACILITIES	12-15
12.4.1	DIGITAL POINTS USED	12-15
12.4.2	LISTS	12-16
12.4.3	SWITCHES & LEDES	12-16
12.4.4	ZONE 1 EQUATIONS	12-16
12.4.5	ZONE N EQUATIONS	12-17
12.5	APPENDIX E - 4100-1282 AZF SWITCH & LED PHYSICAL ADDRESS MAPPING	12-19

1 Introduction

1.1 About this Manual

This manual provides information for creating and maintaining configuration files that contain site-specific information for 4100U-S1 installations.

This manual does not cover how to install or configure hardware items. Refer to LT0394 4100U-S1 Installation and Maintenance Manual for details about this.

This manual does not cover configuration of networked 4100U-S1 systems. Contact your Simplex dealer for assistance with this.

The manual is divided into the following chapters:

- Chapter 2 describes the 4100U-S1 system hardware and how this affects the configuration procedure.
- Chapter 3 describes the 4100U programming tools used for creating and updating the configuration for a 4100U-S1.
- Chapter 4 details the procedure for creating a configuration file for a new 4100U-S1 installation, using the configuration templates.
- Chapter 5 describes how to add addressable devices to the configuration for the in-built IDNet loop.
- Chapter 6 details the configuration settings for addressable devices and how these affect the operation of the devices.
- Chapter 7 describes how to add zone display modules for more zones to the configuration. This is for when an existing system is being extended to have more zones.
- Chapter 8 describes how to add expansion modules such as a second IDNet loop to the configuration. This will apply to a new system which has additional modules over the basic 4100U-S1, or to an existing 4100U-S1 installation that is being extended.
- Chapter 9 describes how custom control equations are written and entered. Some examples are given.
- Chapter 10 describes how to configure the panel to control AS1668 Fans.
- Chapter 11 describes how to build the configuration and download it to the panel.
- Chapter 12 contains appendices which describe how AS4428.1 operation is produced in 4100U-S1 using Custom Control equations. This is for reference only, and is not required reading for normal configuration work.
 - Appendix A – a general description of AS4428.1 requirements.
 - Appendix B – describes the allocation of internal system resources and custom control for system-wide functions.
 - Appendix C – describes custom control for control key and indicator operation on the keyboard.
 - Appendix D – describes custom control for Alarm Zone Facility operation.

2 System Overview

2.1 General Description

The 4100U-S1 is a configuration of the well-established 4100U fire alarm system. It is aimed at applications requiring only one or two loops of Simplex addressable devices.

This is a fully functional 4100U system, but packed and configured in a way that will meet the requirements of most small addressable installations “out of the box”. The options for expansion have been limited so that installers do not need to grapple with all the configuration possibilities of a larger system.

4100U-S1 retains the standard 4100U features, such as: enhanced CPU with dual configuration programs, convenient service port access, and module level earth fault search to locate and isolate faults to assist installation and service. It is fully compatible with existing 4100U networks and modules.



The 4100U-S1 comes in a 21U cabinet with external dimensions 1050 x 575 x 280mm (H x W x D), with a cream wrinkle finish.

In the upper part of the cabinet is a CPU bay containing the 4100U CPU card, its motherboard, and the Australian SPS power supply module. The SPS module provides the first IDNet loop and is fitted with an Alarm Relay card (for alarm/fault/isolate brigade signalling) and a 24V fused distribution board as standard. Up to two 4100 legacy style cards and motherboards can be added to this bay.

Below the CPU bay is the expansion bay which is supplied fitted with Alarm and Isolate indicators and controls for 16 zones. The number of indicators is expandable up to 64 zones by adding LED modules (8 zones each) and a second 64 LED/Switch controller if more than 32 zones are required.

Internally, the expansion bay is empty except for a switched power outlet to supply the SPS and other service requirements. There is space for up to six 4 x 5 modules in this bay. In practice, a 4100U-S1 system will usually run out of zone display space or battery capacity before all these positions are filled. If required, up to four 4100 legacy style cards and motherboards can be added to the expansion bay, depending on how many 4 x 5 modules are also fitted.

Generally each module fitted into the 4100U-S1 is a "Slave" card that is controlled by the CPU card in the loop bay. Each slave is allocated a unique address so the Panel Master CPU can address it. The configuration programmed into the 4100U defines the slave card type at each address and the devices on its loop.

The 4100U programmer has built-in rules about what modules can be installed in each bay of the cabinet.

THIS PAGE IS INTENTIONALLY BLANK

3 About the Programming Tools

3.1 General

The 4100U Panel can be programmed and downloaded with a configuration to meet the desired site installation requirements. The configuration determines every aspect of the fire system operation, e.g., the number of detectors on each loop, their type, their address, their zone, the fire alarm and fault management, isolation, etc.

3.2 4100U Programmer

The programmer for the 4100U panel is a Windows based application with graphical interface that enables the user to build a specific site configuration (job) and download the configuration image into the 4100U panel via the PC serial port.

The programmer operation is controlled by a Programming Key (Dongle) that must be attached to either the PC parallel port or USB socket (depending on the dongle type) to enable programming access.

It is essential to use the 4100U Programmer version that matches the Panel Master Exec version. The following table summaries the compatibility of the 4100U Programmer versions with the 4100U Panel Exec versions.

Panel Exec Version	Programmer Version	Programmer Part Number
11.11.01	11.11.01	SF0371
11.11.02J1	11.11.02J1	SF0380

The appropriate programmer can be ordered from Simplex Fire Products using the part number listed.

3.3 4100U-S1 Configuration Template

The 4100U-S1 panel is shipped with a basic configuration to meet the Australian standard. This includes minimal hardware settings, zone definitions, point definitions and custom control equations to suit the 4100U-S1. This configuration template (part number SF0369) can be used by installation technicians as the basis for each new 4100U-S1 site-specific configuration. Included are a number of different size configurations (number of front panel zones), that are usually adjusted by removing un-necessary zones and adding the additional information.

3.4 4100U Programmer Installation & Launch

Log on to the computer as an administrator and then run the 4100U Programmer installation executable and follow the instructions – this will install the new programmer (with other 4100U programming utilities) on your PC. There is no need to uninstall any old versions as multiple versions can co-exist simultaneously. In fact it can sometimes be useful to have different versions of the programmer installed to support the different Panel Exec versions in the field.

The installation process will create a directory named after the Programmer's version (e.g. Version 12.01.03) under the 'C:\Program Files\Simplex\4100U Programmer' directory.

To launch the programmer click Start | (ALL) Programs | Simplex | the appropriate version number | 4100U Programmer.

3.5 Steps to Configuring a New System

The steps to configuring a new system are covered in Sections 4 -10.

Section 11 contains details on “building” the configuration and downloading it into the panel.

3.6 Upgrading an Existing Configuration

The configuration must be prepared/edited using a version of the programmer that matches the Panel Exec firmware installed. If the panel Exec firmware is updated, e.g. to add some new features, then the configuration will need to be upgraded using the new compatible programmer version and downloaded to the panel after the firmware has been updated.

A panel with a non-matching configuration will report that the existing configuration is an incompatible version and repeatedly restart. The upgraded version of the configuration must be downloaded before normal operation will resume.

Locate the existing database file (job *.SDB4100U) for this system. If you want to keep the old version as well as the upgraded version of the configuration, you may open it using the old Programmer - do a ‘Save As’/‘Copy...’ and enter a new job name for the upgraded version, or simply copy the entire directory of the old configuration to a backup directory. Open the database file using the Programmer with the new version required. The Programmer will identify that the database is an older version and will prompt to do an upgrade.

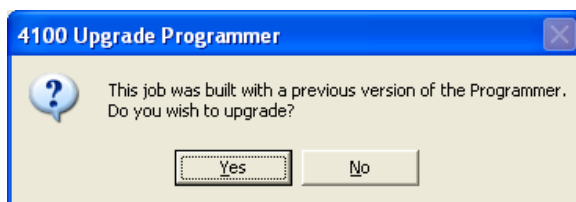

Click on the Yes button.

This will upgrade the database to the format for the new programmer version. Make any changes required, save the new database, build it and download it to the panel as described in this manual.

THIS PAGE INTENTIONALLY LEFT BLANK

4 Creating a Configuration

4.1 Creating a New Project File

This method describes how to create a new 4100U-S1 configuration using the template configuration file as the starting point. Run the 4100U programmer of the correct version and click on the 'File' menu and select 'Open'.

Browse to the location containing the 3 default configurations supplied with SF0369:

S1_16ZN.SDB4100U for 16 zones,

S1_32ZN.SDB4100U for 32 zones or

S1_64ZN.SDB4100U for 64 zones.

Choose the one that has more front panel zones than are required as it is easier to remove extra zones rather than add more. Click OK.

After the file is opened do a 'Save As'/'Copy...', enter the new job name and click OK. Note that the 'Job Name' you enter will show on the front panel when the "**Display Software Revision Level**" command is entered.

Now proceed with adding and modifying the site specific information as described below.

4.2 Adding Panel Information

Enter the relevant information on the 'General Info' page in the 'Panel' tab.

- Description = Site name.
- Project Number = Software job number (must be obtained from Simplex).
- Order number = Clients order # for the panel.
- Agency listing = Should always be - SSL/CSIRO.
- NFPA = (not required).
- Hours of standby battery = Should be 24 unless not brigade connected.
- A/C breaker location = (fill in if known).
- Branch number = (not required).
- Branch location = Simplex office location.
- Contact = If programmed by contractor put in Simplex contact name (could be sales person or tech etc).
- Sales person = If Simplex put in sales person's name.
- Project Eng = (not required).
- Technician = If Simplex programming put in your name (technician).
- Customer = Building owner (if known).
- Contractor = Contractor company name.
- Programmed by - Appropriate field to be filled in i.e. if programmed by Simplex we fill in branch name file and phone.
- If programmed by contractor they fill in Customer name title and phone.
- Hardware lock enable = leave unchecked.
- Comment = Further information like panel location.

To enter the panel CPU serial number click on the 'Panel' tab, then click on the 'Features' page. Then tick the 'Runtime Enable Edit' checkbox. Enter the serial number of the panel CPU in the text entry field labelled 'CPU #', and then click on the 'Update Access Codes' button.

If the CPU Serial number is not known then power up the panel - the CPU Serial Number appears on the initial screens displayed during the panel startup. If the panel is not available, leave the CPU serial number empty for now. If you try downloading the configuration to a panel without entering the serial number, or it is wrong, a warning will be given but you can still complete the process. Once the number is known, enter it and download the configuration.

4.3 Adjusting the Number of Zone Displays

To delete unnecessary front panel display zones:

- Click the Custom Control tab.
- Open Program 4 (labelled as 'AS4428 CONTROL LOGIC ZONES 1 - xx').
- Scroll down to display the last zones' equations.
- Highlight the equations for the unused zones using the Shift and Down Arrow keys. Each zone is comprised of 6 custom control equations that are labelled with that zone number.
- Press the 'Delete' key and then the 'y' key repeatedly to acknowledge the deletion of each equation.

4.4 Adding the AZF Logic

The Alarm Zone Facility logic (the custom control equations for the zones) should not need to be modified unless new hardware is added to the panel, e.g., when extending an existing 4100U-S1 panel with 16 zones to 32 or 64 zones, etc. Note this may require an additional 64 LED/switch controller (4100-1288) and LED/switch modules (4100-1282) to be installed in the panel. This programming is described in Chapter 7.

4.5 Where to Next?

New systems have to be configured with the addressable devices, and the devices assigned to zones. This is covered in chapter 5.

THIS PAGE INTENTIONALLY LEFT BLANK

5 Adding Addressable Devices

5.1 General

5.2 Adding devices to an SPS Addressable Loop

The 4100U-S1 panel is supplied with one addressable loop. This loop is located on the SPS Power Supply.

To add addressable devices to this loop using the programmer follow these steps.

- Select the *HARDWARE* Tab
- Click on the “+” sign beside Unit 0
- Click on the “+” sign beside Box 1
- Click on the “+” sign beside Bay 1

Double click on the green card beside the text:

“(PS QUAD (Slots 5-8))[001]
 4100U/5113 – SPS_240V_DOM M1-1
 – 1-3, SIG3 – 5, AUX 3-4”

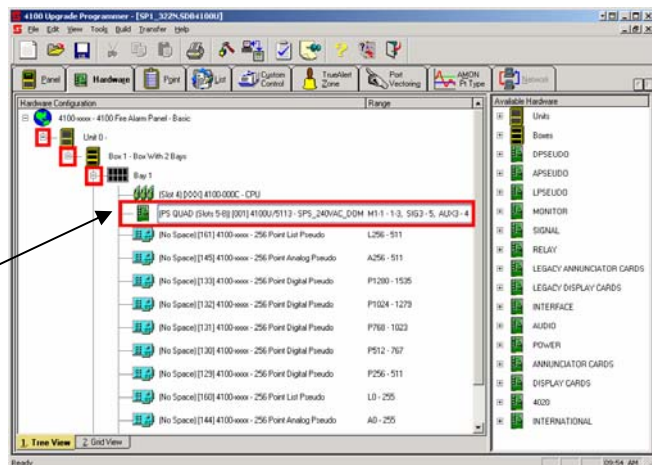

- Select the *IDNET* Tab



- Select the desired address of the device by clicking on the line.

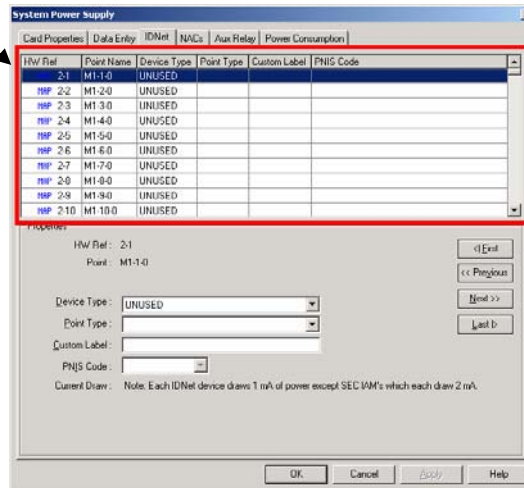

- Select the *Device type*

Refer to Section 6.2 for Device type options

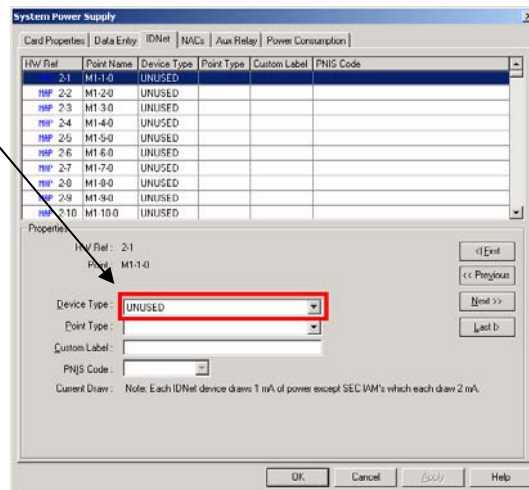

- Select the *Point type*

Refer to Sections 6.2 for Point type options

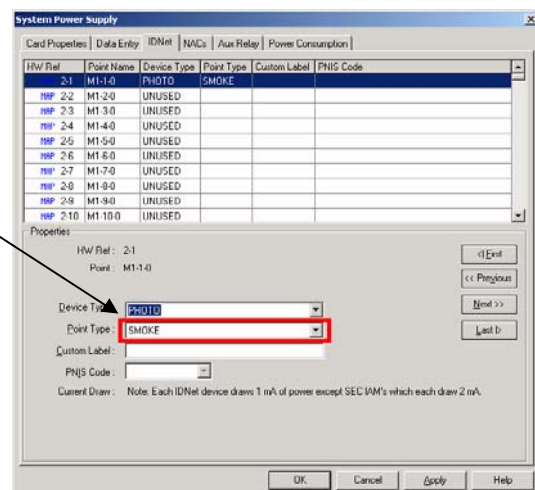

- Enter Custom Label

The Custom Label is limited to 40 Characters. It is recommended that the last 4 characters be used to denote the zone the point belongs to. E.g..

<Description of Point Location>__ZN01

- To continue entering new devices click the APPLY or NEXT buttons.

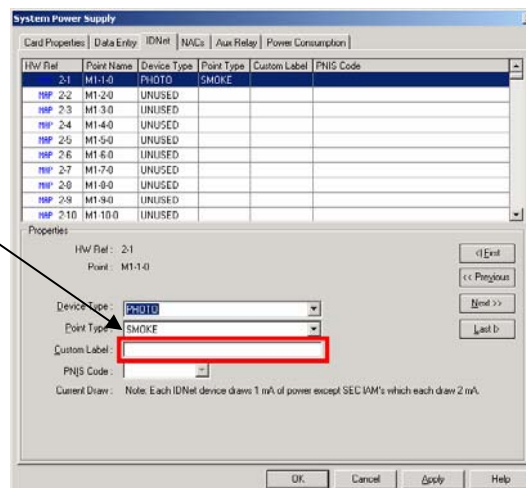

5.3 Assigning Devices to Zones

Once addressable devices have been entered into the configuration (refer Section 5.2) they can then be assigned to Zones on the 4100U. This is done by adding the device to preset Lists as follows:

- Select the LIST tab

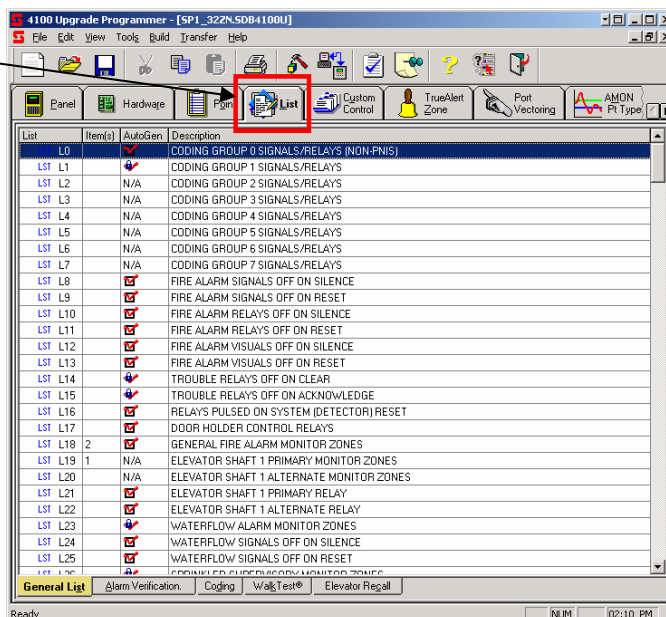

- Scroll down until L261 is reached.
L261 = Zone 1
L260+n = Zone n

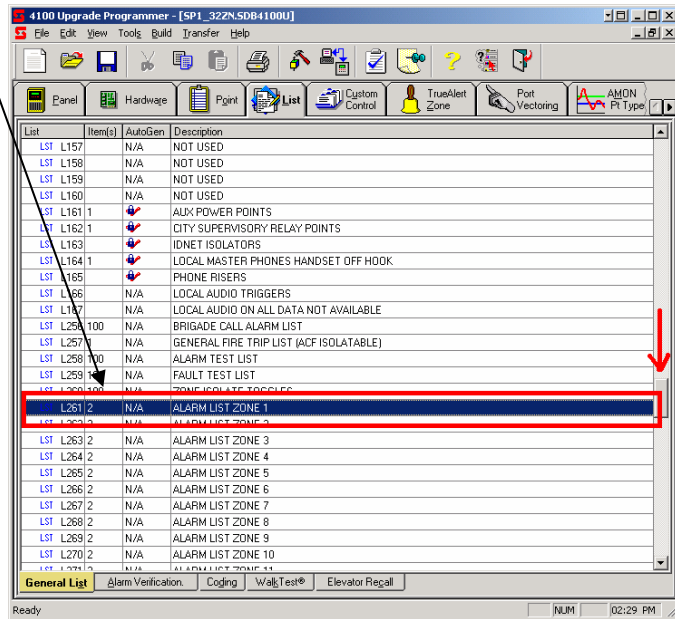

- Once the correct List is highlighted press **F9** to display the points assigned to this list. The zone list should always have at least two points assigned: the Alarm Test and Fault Test points.

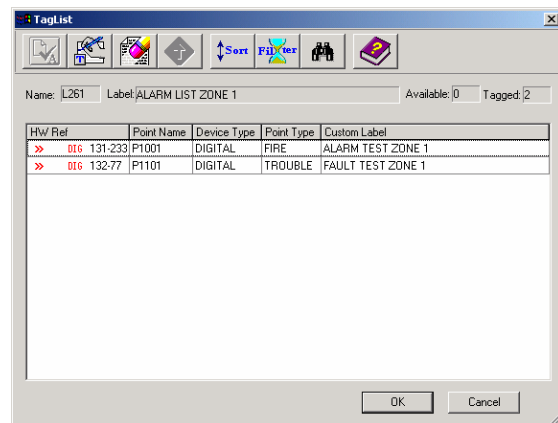

- Click on the **Filter** button

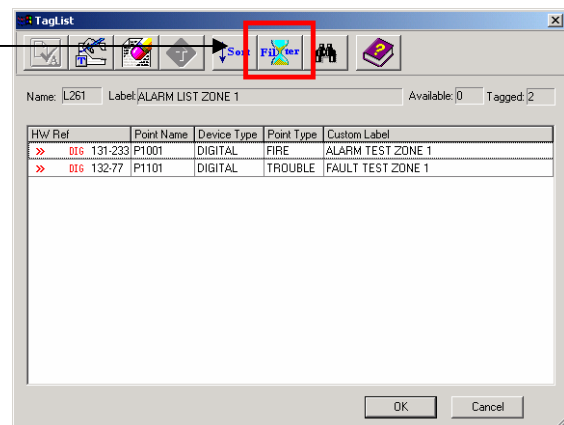

- Select the *MAPNET/IDNet* option

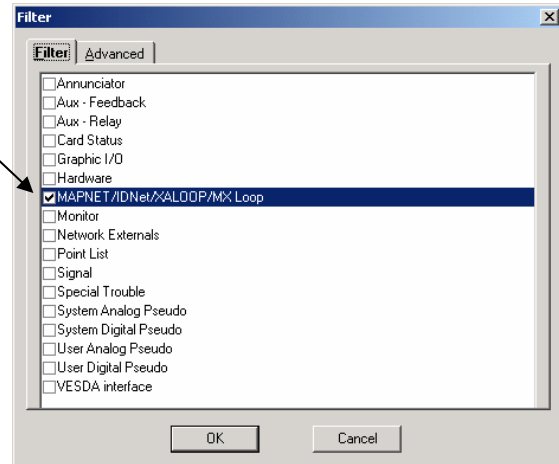

- All available addressable devices (MAPNET, IDNet, etc) will now be listed in the TagList window.

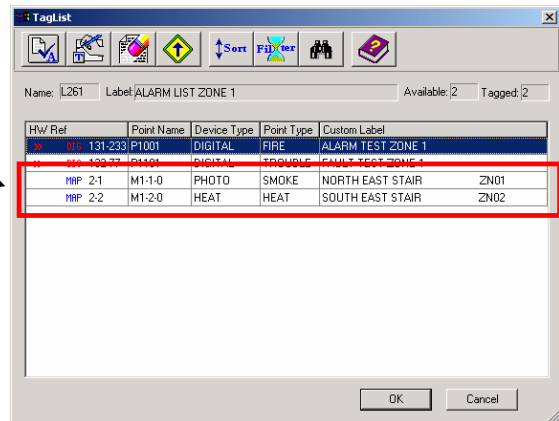

- Select the required devices by highlighting the device and pressing the <SPACEBAR>. Two red chevrons ">>" indicate the device has been selected.
- Press OK when all devices are selected for this zone.

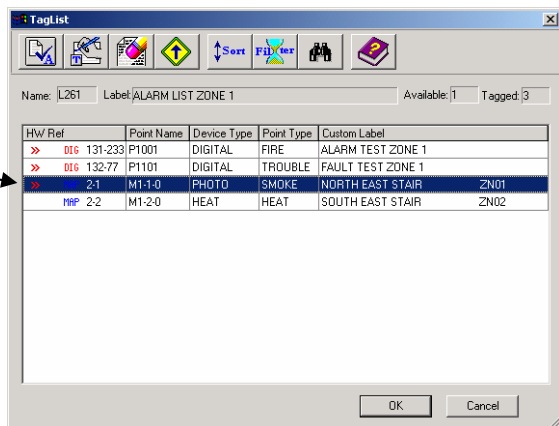

6 Addressable Device Settings

6.1 Introduction

6.1.1 Alarm Device Types

The 4100U-S1 supports a range of addressable device types on its IDNet addressable loops. The following sections detail for each of the compatible addressable devices (detectors and modules) what device type and what point type should be selected in the 4100U programmer. The device type defines what type of device it is, including, for detectors, what type of base is used. The point type defines how the device is to be used, i.e. the functionality or application.

6.2 Addressable Detector Settings

6.2.1 4098-9714E Photo Detector

Device Types

PHOTO	– Standard photo detector on Standard base
IPHOTO	– Standard photo detector on Isolator base
RPHOTO	– Standard photo detector on Relay base
SPHOTO	– Standard photo detector on Sounder base

Point Types

SMOKE	– Standard setting
VSMOKE	– Verified Smoke Detector
DUCT	– Duct detector

6.2.2 4098-9717E Ion Detector

Device Types

ION	– Standard ion detector on standard base
IION	– Standard ion detector on Isolator base
RION	– Standard ion detector on Relay base
SION	– Standard ion detector on Sounder base

Point Types

SMOKE	– Standard setting
VSMOKE	– Verified Smoke Detector

6.2.3 4098-9733E Heat Detector

Device Types

HEAT	– Standard heat detector on standard base
IHEAT	– Standard heat detector on Isolator base
RHEAT	– Standard heat detector on Relay base
SHEAT	– Standard heat detector on Sounder base
OHEAT	– Standard heat detector with Rate of Rise on standard base
IOHEAT	– Standard heat detector with Rate of Rise on Isolator base
ROHEAT	– Standard heat detector with Rate of Rise on Relay base
SOHEAT	– Standard heat detector with Rate of Rise on Sounder base
UHEAT	– Heat detector that can only be used as a Utility (non-MAF) detector

Point Types

HEAT – Standard setting
UTILITY – Heat detector used for non-MAF usage only

6.2.4 4098-9754E MultiSensor Photo Heat Detector**Device Type**

COMBO – Standard MultiSensor detector on standard base
ICOMBO – Standard MultiSensor detector on Isolator base
RCOMBO – Standard MultiSensor detector on Relay base
SCOMBO – Standard MultiSensor detector on Sounder base

Point Type – Photo Part

SMOKE – Standard setting
VSMOKE – Verified Smoke Detector
DUCT – Duct detector

Point Type – Heat Part

HEAT – Standard setting
UTILITY – Heat detector used for non-MAF usage only

Point Type – R-Correlation Part

FCOR – Alarm Smoke / Heat Correlation
UCOR – Utility Smoke / Heat Correlation used for non-MAF usage only

6.3 Addressable Device Settings

6.3.1 4099-9032 MCP

Device Type

KACPULL – Standard MCP

Point Type

PULL – Standard setting

6.3.2 4090-9001 Supervised Input IAM or 4090-9051 Encapsulated Input IAM

Device Type

IAM – Standard setting

Point Type

FIRE – General Fire Point.
UTILITY – Input used by Custom Control Logic only
TROUBLE – Input used to indicate a Fault status

6.3.3 4090-9002 Relay IAM

Device Type

RIAM – Standard Setting

Point Type

RELAY – General Purpose relay.
RRELAY – Relay on until panel Reset
TRELAY – Fault Relay on until fault cleared

6.3.4 4090-9101 Monitor ZAM

Device Type

MBZAM – Standard Setting

Point Type

FIRE – Standard setting

6.3.5 4190-9050 4-20mA Analog Monitor ZAM

Device Type

ANAMON – Standard Setting

Point Type

The Point Types are custom configurable using the *AMON Pt Type* Tab. The Point types need to be configured before the 4190-9050 is added.

6.3.6 4090-9118 Relay IAM with T-Sense Input

This device has multiple sub points. The sub points can have the point type changed depending on the operation.

Mx-x-0 Parent Point

Device Type

TRIAM – Standard setting

Point Type

UTILITY – Standard setting

Mx-x-1 1st Sub Point (relay output)

Device Type

MRELAY – Fixed Device type

Point Type

RELAY – General Purpose relay.
RRELAY – Relay on until panel Reset
TRELAY – Fault Relay on until fault cleared

Mx-x-2 2nd Sub Point (T-Sense input)

Device Type

MTSENSE – Fixed Device type

Point Type

FIRE – General Fire Point.
UTILITY – Input used by Custom Control Logic only
TROUBLE – Input used to indicate a Fault status

6.3.7 4090-9119 Relay IAM with Unsupervised Input

This device has multiple sub points. The sub points can have the point type changed depending on the operation.

Mx-x-0 Parent Point

Device Type

FRIAM – Standard setting

Point Type

UTILITY – Standard setting

Mx-x-1 1st Sub Point (relay output)

Device Type

MRELAY – Fixed Device type

Point Type

RELAY – General Purpose relay.
RRELAY – Relay on until panel Reset
TRELAY – Fault Relay on until fault cleared

Mx-x-2 2nd Sub Point (feedback input)

Device Type

MFEEDBK – Fixed Device type

Point Type

UTILITY – Input used by Custom Control Logic only
TROUBLE – Input used to indicate a Fault status

6.3.8 4090-9120AU 6 Point I/O Module (4 Inputs, 2 Relay outputs)

This device has multiple sub points. The sub points can have the point type changed depending on the operation.

Mx-x-0 Parent Point

Device Type

MLPTIO – Standard setting

Point Type

UTILITY – Standard setting

Mx-x-1 to Mx-x-4 Sub Points (input)**Device Type**

MINPUT – Fixed Device type

Point TypeFIRE – General Fire Point.
UTILITY – Input used by Custom Control Logic only
TROUBLE – Input used to indicate a Fault status**Mx-x-5 and Mx-x-6 Sub Points (relay outputs)****Device Type**

MOUTPUT – Fixed Device type

Point TypeRELAY – General Purpose relay.
RRELAY – Relay on until panel Reset
TRELAY – Fault Relay on until fault cleared**6.3.9 4090-9116 Addressable IDNet Isolator****Device Type**

IDNETISO – Standard Setting

Point Type

ISO – Standard setting

6.3.10 4090-9117AU Addressable IDNet Power Isolator**Device Type**

POWERISO – Standard Setting

Point Type

ISO – Standard setting

THIS PAGE IS INTENTIONALLY BLANK

7 Adding Zone Displays

7.1 General

This chapter describes how to add more zones to the configuration. It applies when an existing 4100U-S1 panel is being upgraded to have more zones and the existing configuration needs to be expanded to control them. Configuring zones for new sites where the configuration is built for the 1st time is described in Chapter 4.

7.2 Zone Control & LED Modules

The basic hardware modules to provide zone LEDs and controls in a 4100U-S1 are:

- 4100-1282 – 8 Pushbuttons/16 Red-Yel LEDs – provides 8 pushbuttons and 16 LEDs.
- 4100-1288/1289 – 64 LED / 64 SW Controller – slave module - controls 64 LEDs and 64 switches i.e. 4 X 4100-1282 modules.

Other LED and switch modules are available for different applications (e.g. ME0456 4-way AS1668 Control Module).

The standard configuration of a 4100U-S1 as it leaves the factory is to have 16 zones, which means 1 X LED/switch controller (4100-1288) and 2 X LED/switch modules (4100-1282) are fitted.

For every additional 8 zones an additional LED/switch module (4100-1282) needs to be fitted and configured, and if the number of zones goes above 32 then an additional LED/switch controller (4100-1288) needs to be configured.

For mounting and wiring instructions for these modules refer to the 4100U-S1 Installation Manual (LT0394).

- Note that when the 2nd LED/switch controller (4100-1288) is to be configured – its address must be set to 4 to match the template configuration.

7.3 Hardware Configuration Modification

To add new Zone Switch/LED and Controller modules to the configuration do the following:

- Select the **HARDWARE** Tab
- Click on the “+” sign beside **Unit 0**
- Click on the “+” sign beside **Box 1**
- Click on the “+” sign beside **Bay 2**
- This will show the currently configured display cards in **Bay 2**.

- Click on the “+” sign beside the **DISPLAY CARDS** option on the **Available Hardware** window.
- Drag and drop the **4100-1282 – 8 Pushbuttons/16 Red-Yel LEDs** icon over the Bay 2 icon.
- An **8 Pushbuttons/16 red-Yel LEDs** module will be added to the configuration.
- Repeat adding more **8 Pushbuttons/16 Red-Yel LEDs** modules as required (up to 8 in total).

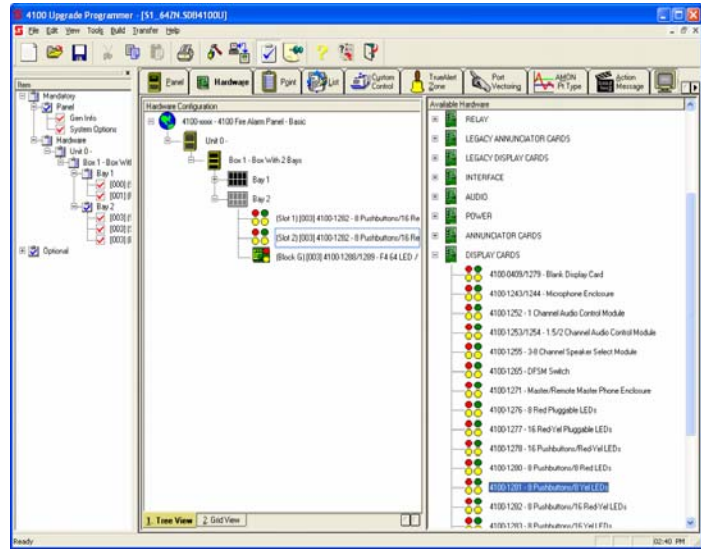

Notice that if more than 4 modules are configured then the 5th and higher will appear with a ‘[??]’ sign as follows:

This means that the configuration requires an additional **4100-1288/1289 – F4 64 LED / 64 SW Controller** to be added.

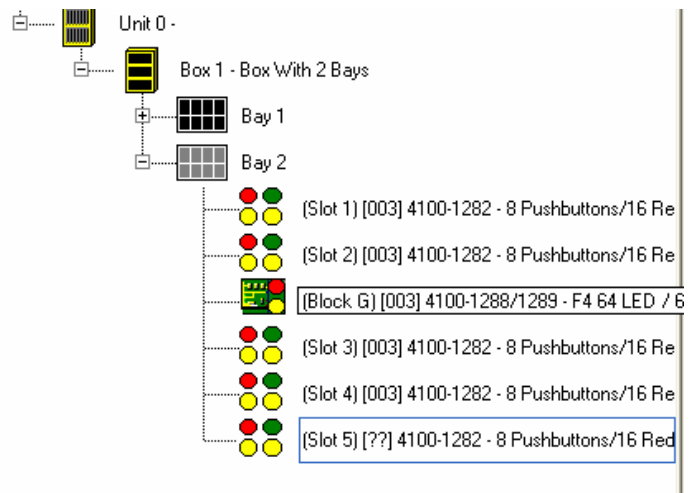

To add the **4100-1288/1289 – F4 64 LED / 64 SW Controller**

- Click on the “+” sign beside the **ANUNCIATOR CARDS** option on the **Available Hardware** window.
- Drag the **4100-1288/1289 – F4 64 LED / 64 SW Controller** Icon over to the **Bay 2** icon and release.

The card will be added to the configuration.

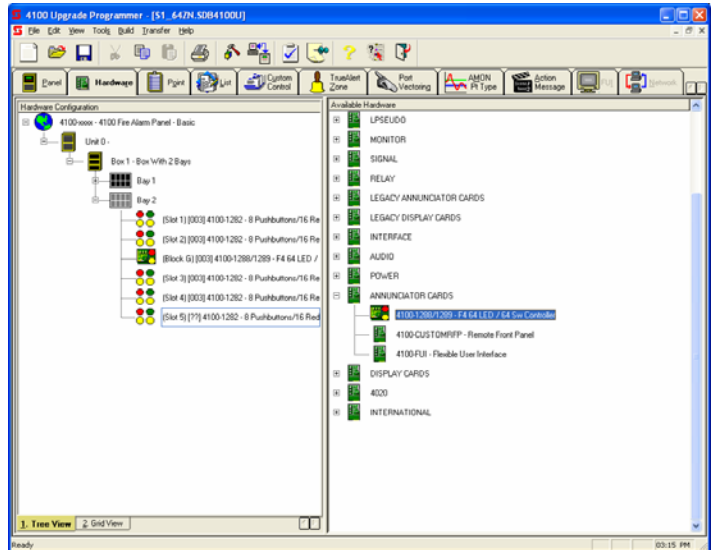

Verify that the card appears with address 4 and that **4100-1282 – 8 Pushbuttons/16 Red-Yel LEDs** modules that previously appeared with ‘[??]’ sign – now appear with address 4 – **[004]**.

Do not change the 2nd LED/Switch Controller from address 4 as this will mean all the custom control equations will need modifying.

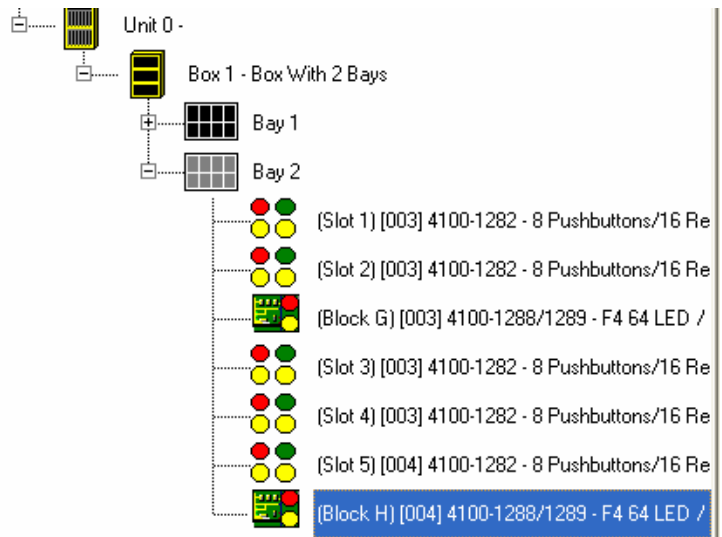

After the new **4100-1282 – 8 Pushbuttons/16 Red-Yel LEDs** cards have been installed configure their **SW Mode** and **Ref Address**:

Double click on the card and enter the **Card Properties** tab. Enter the **Card Custom Label** text box with appropriate name.

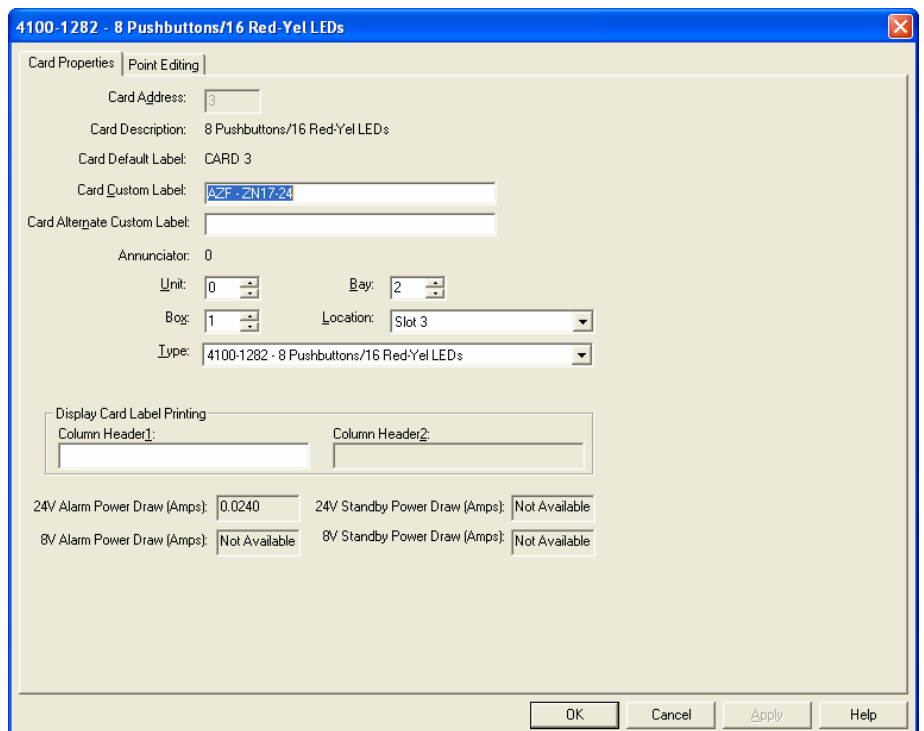

Then go to the **Point Editing** tab and edit the points: On the **Switch** side, for each point, configure **Mode:** as **PBT** and on the **LED** side configure **Mode:** for odd addresses as **SMPL** and for even addresses as **ON**.

For both sides (the **Switch** and **LED**) configure the **Reference Address:** as detailed in Section 12.5.

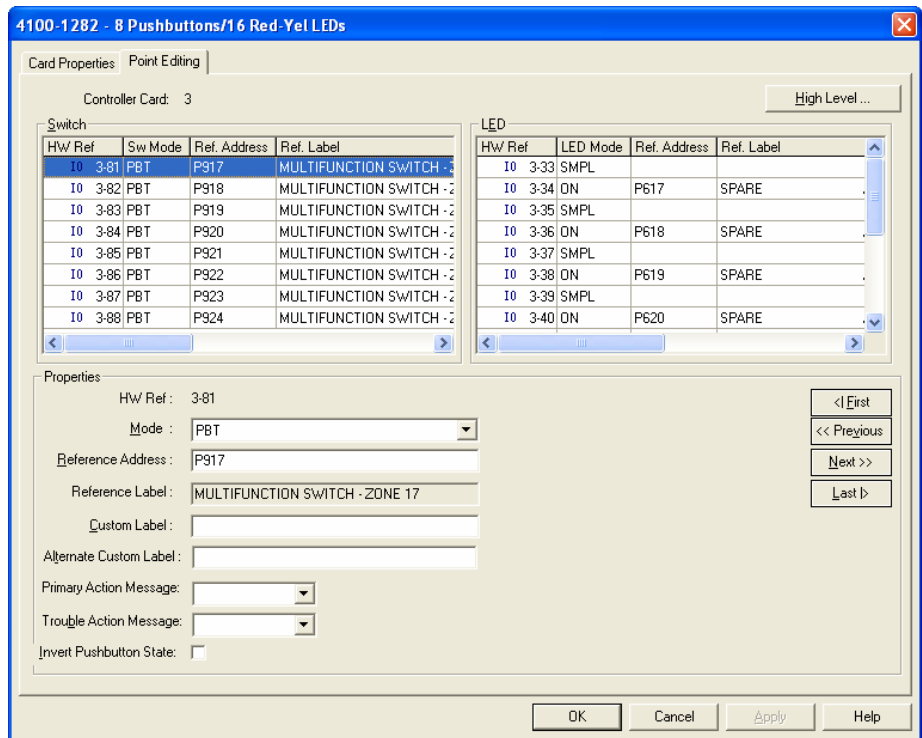

7.4 Modify the Custom Control Equations for the Zones

The simplest method to add more custom control equations for the new displays is to open a 32 or 64 zones template and export the custom control equations for the zones, then from within the original site configuration import these equations. The detailed steps are as follow:

1. Click on the '**File**' menu and select '**Open**'.

Browse to the location containing the 3 default configuration templates supplied with SF0369 and select the S1_64ZN.SDB4100U configuration if more than 32 zones (up to 64) are needed, or select S1_32ZN.SDB4100U if the configuration should include up to only 32 zones. Click **OK**.

2. Click on the '**Custom Control**' tab.

Right Click on **Program 4** and select '**Export Program...**'.
Save the exported .CC4100U file in an accessible location. .

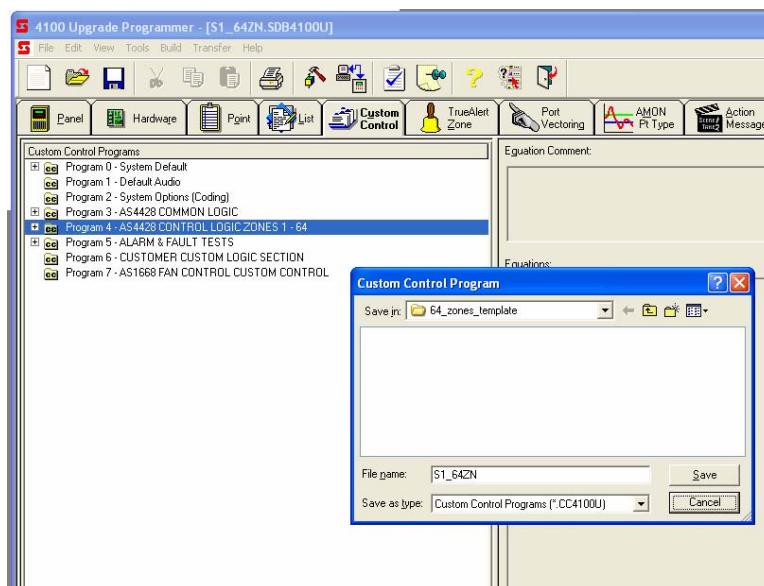

At the end of the export process a message with the process status will appear with the export result.

Click the OK button.

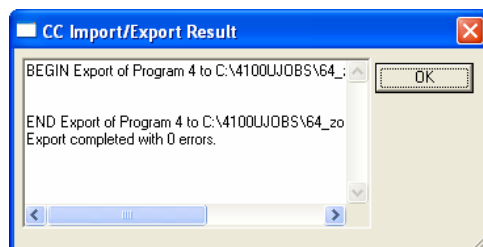

3. Close the template and re-open the site configuration database.

4. Click on the '**Custom Control**' tab.

Right Click on **Program 4** and select '**Import, Append Program...**' .

Browse to the location where you saved the exported .CC4100U file, select it and click '**Open**'.

The import process will start.

At the end of the import process, a message with the process status will appear with the import result.

Click the OK button.

- Note: the import process message box may display errors if the hardware configuration does not match the number of zones. E.g., in the case where the hardware configuration modification (see 7.3) included only 48 zones and custom control equations referring to zones 49-64 use undefined points.

Delete any unnecessary equations for zones that are not present, as described in Section 4.3.

Rename program 4 to reflect the modification. This is done by right click and selecting 'Properties...' and editing the 'Label:' text box to have the correct zone range.

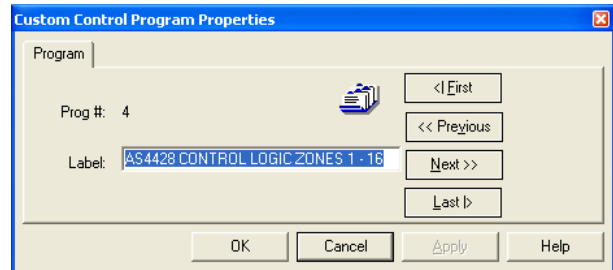

Finally do a 'Build' to the new configuration which should result with no errors.

THIS PAGE IS INTENTIONALLY BLANK

8 Adding Expansion Modules

8.1 General

This section describes the procedure to configure the panel with additional modules which may be added to the panel if additional control should be carried. It describes the concept and method of adding modules by giving detailed examples of 3 cards: IDNet, 6 Supervised Relay and Dual RS232 printer card.

Each slave card must be assigned a unique address so the CPU card can communicate with it. When a new slave is added it will automatically be assigned the next unused address.

- Note that all additional cards must use address 5 or above since addresses 0-4 are reserved as follows:

- #0 – CPU card
- #1 – SPS card
- #2 – IDNet card that is embedded on the SPS
- #3 – First 64 LED / 64 SW Controller
- #4 – Optional second 64 LED / 64 SW Controller

Therefore, when adding the first extra slave, do not use address 4, unless the slave is the second 64 LED/Switch Controller.

8.2 Adding 4100-3101 IDNet Loop Card

If more than 250 devices are required or two physical loops are needed an additional **4100-3101 IDNet Addressable Loop** card can be added to the panel. For mounting instructions refer to the documentation supplied with the module and LT0394 4100U-S1 Installation Manual.

Before any devices can be added to the panel's configuration the new 4100-3101 card must be added as follows:

- Select the **HARDWARE** Tab
- Click on the “+” sign beside **Unit 0**.
- Click on the “+” sign beside **Box 1**.
- Click on the “+” sign beside **Bay 2**.

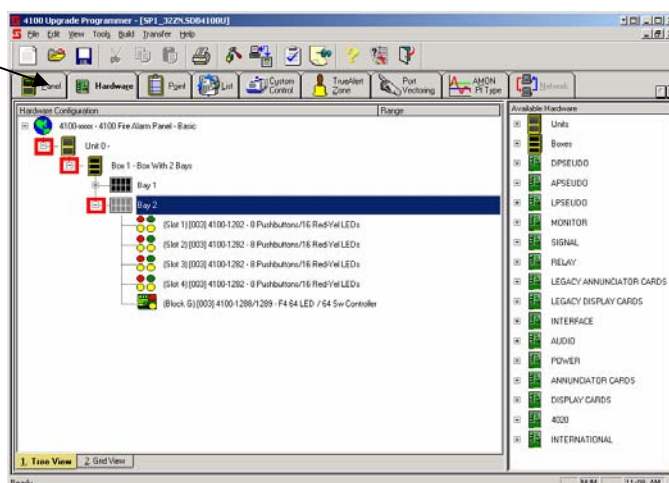

- Click on the “+” sign beside the **INTERFACE** option on the **Available Hardware** window.
- Drag and drop the **4100-3101 – IDNET 250 Points** icon on to the **Bay 2** icon.

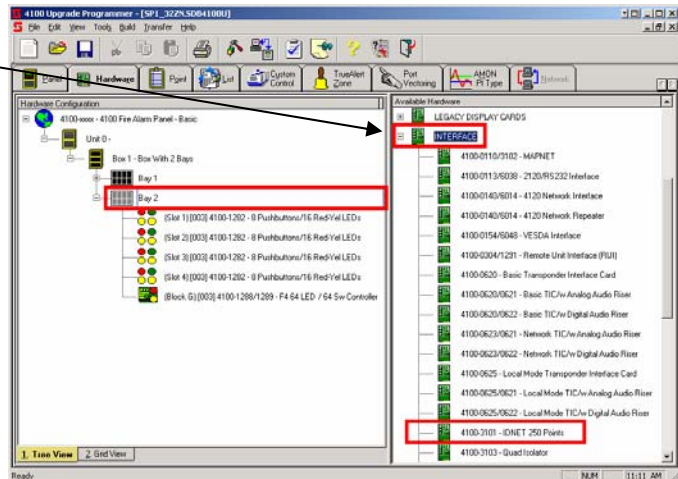

- An IDNET card will be added to the panel configuration.
- **Block H** represents the location in the bay, but this is not relevant for the 4100U-S1.
- **[004]** is the address of the card and **MUST** match the physical address on the IDNET module. **WARNING:** Use Address 5 or higher.
- **4100-3101-IDNET 250 Points** is the type of the card.

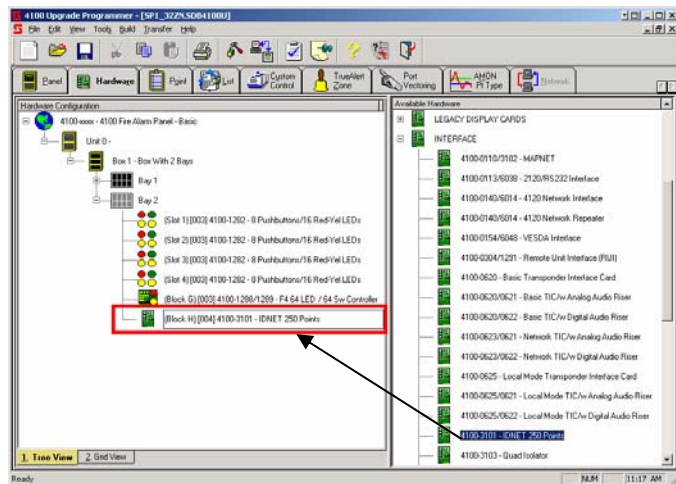

Now that the new IDNet card has been added, the addressable devices connected to this card can be added to the panel configuration as follows:

- Select the **Point Editing** Tab.

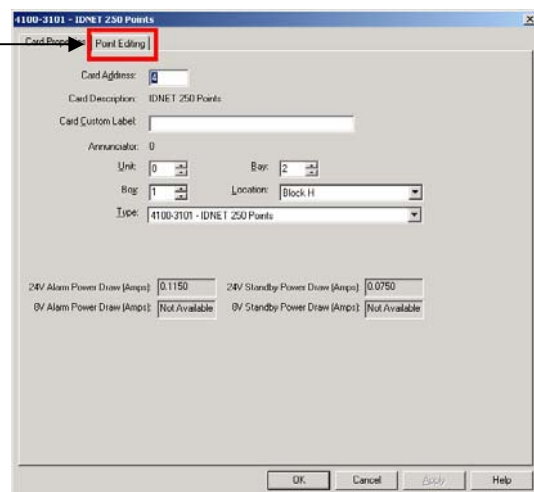

- Select the desired address for the device. →

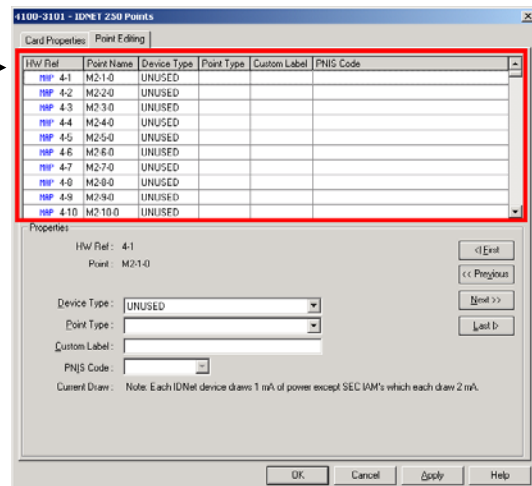

- Select the **Device type**
 Refer to Section 6.2 for Device type options.

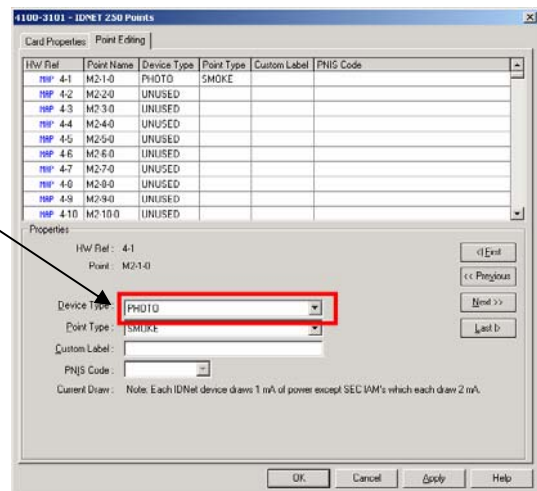

- Select the **Point type**
 Refer to Section 6.2 for Point type options.

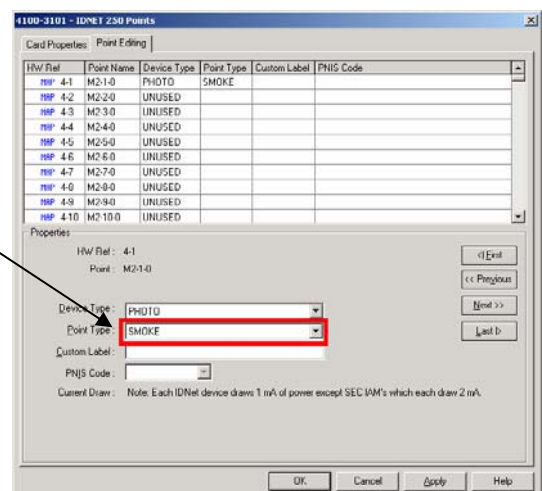

- Enter a Custom Label.

The Custom Label is limited to 40 characters. It is recommended that the last 4 characters be used to denote the zone the point belongs to. E.g.

<Description of Point Location>___ZN01

- To continue entering new devices click the **Apply** or **Next** buttons
- The devices can then be added to zones as described in Section 5.3.

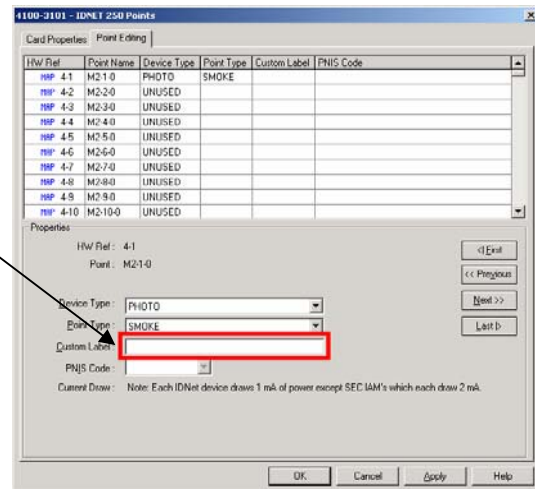

8.3 Adding 4100-4321 Legacy Signal Card

The 4100-4321 6 Supervised Relay module provides 6 supervised output control (signal) circuits. The 6 circuits have two power inputs: one power input for every three signal circuits. Each of the signal circuits is supervised for ground faults, opens and line-to-line shorts.

The card is added as follows:

- Select the **HARDWARE** Tab.
- Click on the “+” sign beside **Unit 0**.
- Click on the “+” sign beside **Box 1**.
- Click on the “+” sign beside **Bay 2**.
- Click on the “+” sign beside the **SIGNAL** option on the **Available Hardware** window.
- Drag and drop the **4100-4321-3 Input Class B Sig** icon over to the **Bay 2** icon.

The card will be added to the panel configuration.

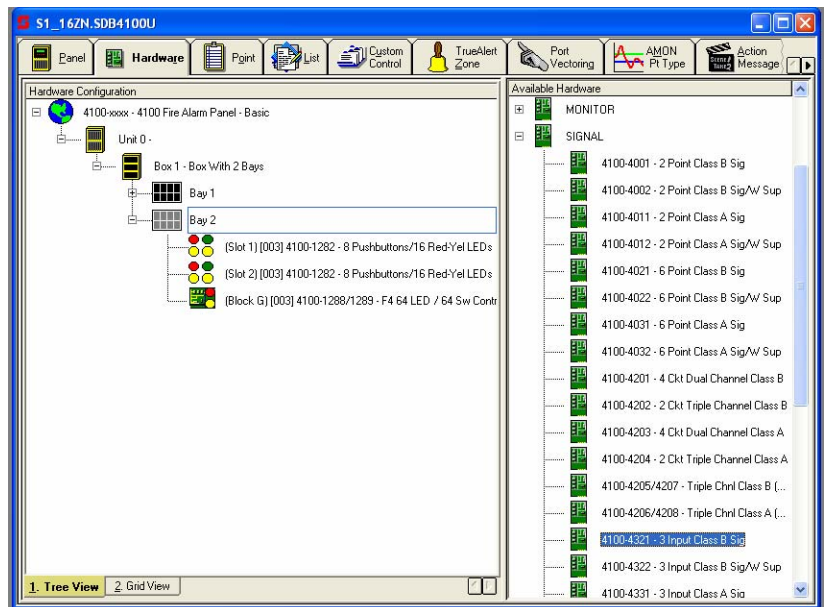

Double click on the card and in the **Card Properties** tab adjust its address to be greater than 4, then in the '**Card Custom Label:**' text box, enter a descriptive label.

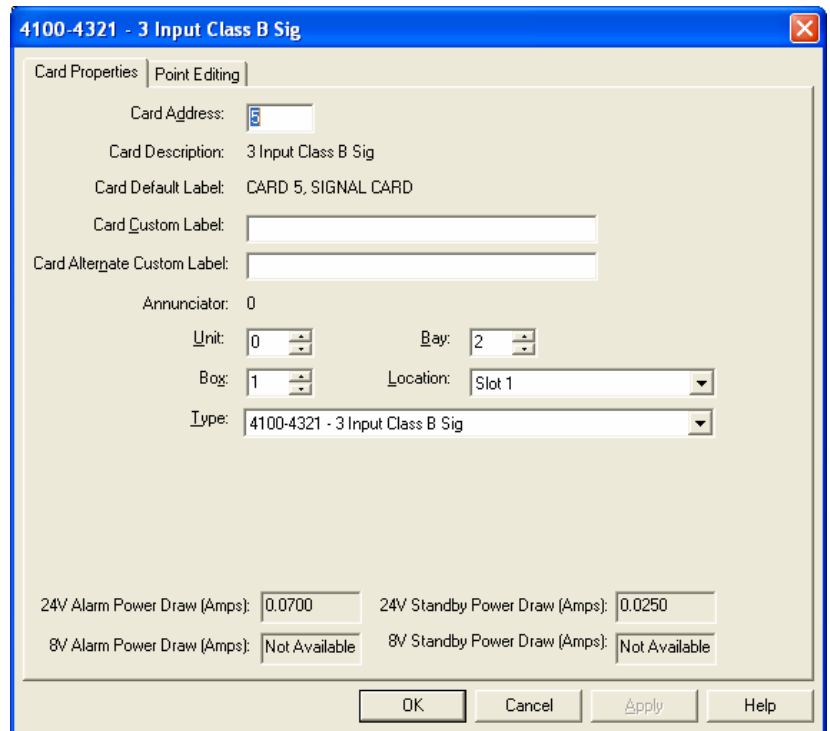

Click the **Point Editing** tab and record the points' names. These names are used to control the outputs within user defined Custom Control equations as in the following example for SIG9.

```
[INPUTS]
  STATUS ON
    L257 | LIST | DPSEUDO | GENERAL FIRE
  TRIP LIST (ACF ISOLATABLE)
[END INPUTS]
[OUTPUTS]
  TRACK ON PRI=9,9
    SIG9 | SIGB | SSIGNAL | SIGNAL CARD 5
  CIRCUIT SIG9
[END OUTPUTS]
```

Refer to Chapter 9 for information on writing custom control equations.

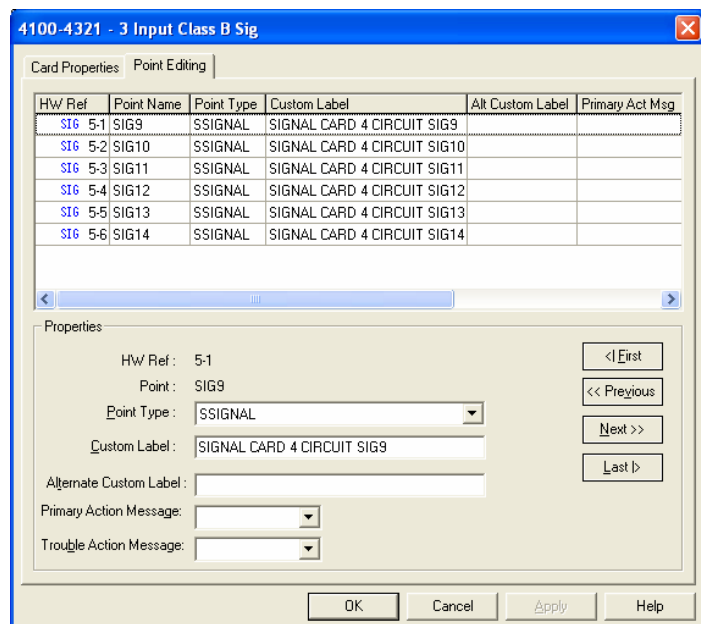

8.4 Adding Legacy Card – 4100-0113 RS-232/2120 Interface Module

The 4100-0113 RS-232/2120 Interface Module provides two RS-232-C outputs (Port A and Port B) that can be configured for remote printers, CRT, or as a Computer Port for communications to a remote system (e.g. BMS or BAS Systems).

To add the 4100-0113 RS-232/2120 Interface Module to the panel:

- Select the **HARDWARE** Tab.
- Expand the **Unit 0**, 'Box 1' and 'Bay 2'.
- Click on the "+" sign beside the **INTERFACE** option on the **Available Hardware** window.
- Drag and drop the **4100-0113 RS-232/2120 Interface** icon over to the **Bay 2** icon.

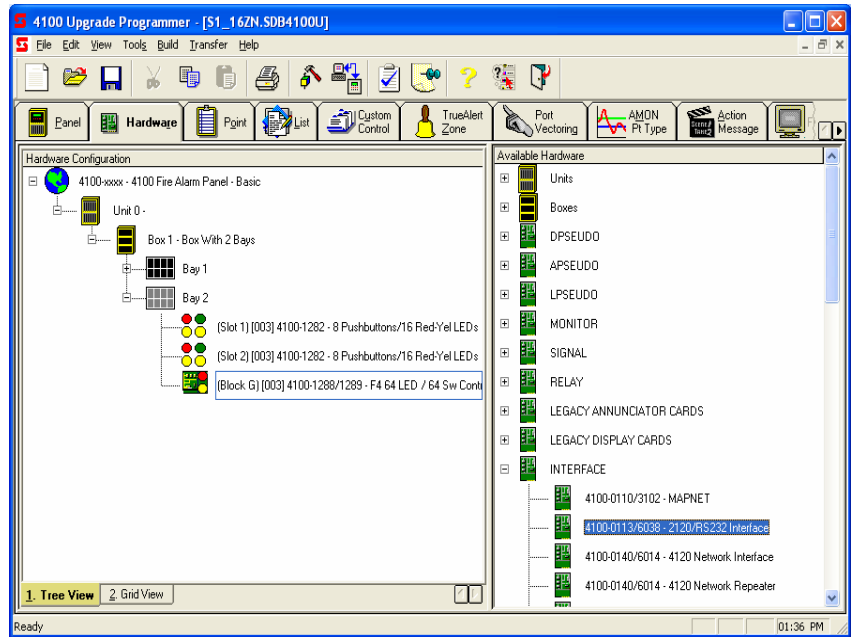

The card will be added to the panel configuration.

Double click on the card and in the **Properties** Tab adjust its address to be greater than 4, then enter in the **Card Custom Label:** text box, a descriptive label.

Set the **Ports** as in the following example for RS232 connection to PC (used for generating printed reports). Adjust the baud rate, etc, if needed.

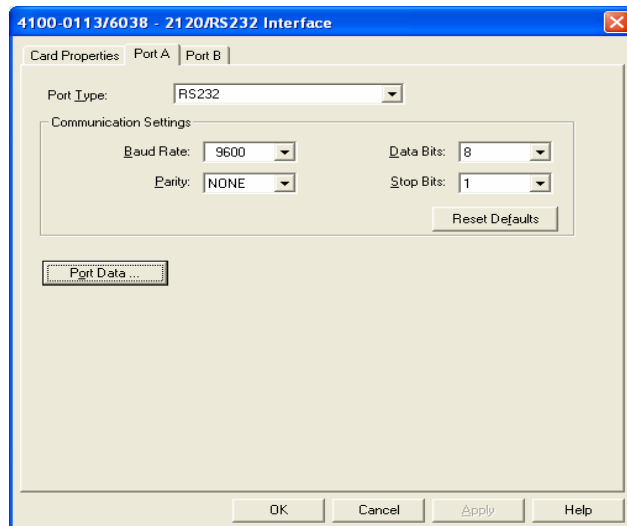

Click the **Port Data...** button and select the desired **Device Type** as in the following example for an 80 column CRT output.

Click OK and again for the previous screen.

Repeat for **Port B** (if used) and select the appropriate device type and baud rate, etc.

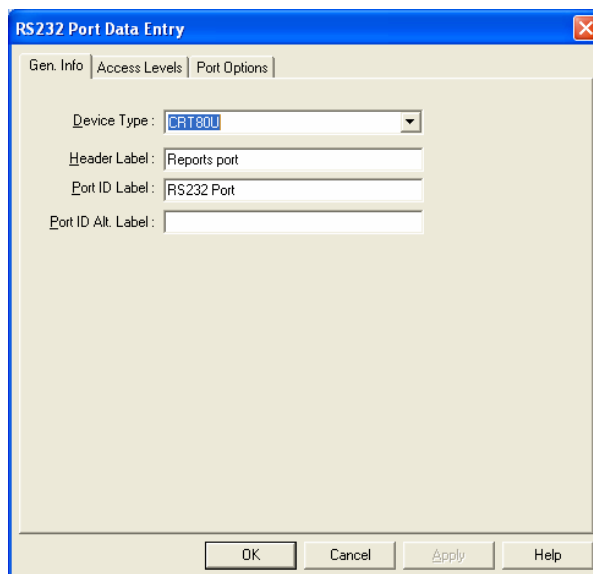

9 Custom Controls

9.1 General

4100U Custom Control Equations provide a way to override the 4100U's default operation. Each Custom Control equation has a similar form: one half of the equation, called the **input** side, is used to monitor the state of specific system inputs (initiating devices, for example). The other half of the equation, called the **output** side, is used to control specific system outputs (relays, addressable devices, etc.). If the input side of the equation is true, then execute the output side.

9.2 Custom Control Syntax

Input Statements are typically used to monitor the status of a point or list, or perform an action such as delay, cycle, compare two values, or save/recall values. Every input statement begins with an *Opcode*, which is the action that the input is performing (for example, monitor point status, recall memory register, etc.). The Custom Control wizard then displays a series of opcode-specific dialogs. For example if the Opcode is Point Status, the dialogs prompt the user for information about the condition (alarm, trouble, etc.) and point being monitored.

```
[INPUTS]
STATUS FIRE
  ZN1 | MONB | FIRE | MONITOR CARD 3 ZONE ZN1
```

Output Statements are the actions that occur only when the input side of the equation is true. Every output statement begins with an *Opcode*, which is the general action that occurs when the input side is true. The opcode is followed by a series of opcode-specific dialogs, which allow you to specify exactly how the selected opcode functions. For example, if you are using the Set Opcode, the wizard displays a series of dialogs that allow you to specify a qualifier (on, off, etc.) and the point (a signal, for example) on which you want the output action to execute.

```
[OUTPUTS]
HOLD ON PRI=9.9
  SIG3 | SIGB | SSIGNAL | SIGNAL CARD 1 CIRCUIT SIG3
```

Logical Operators (AND, OR, NOT) allow you to link multiple input statements to form logical expressions. Logical operators are only used with input statements and are not used with Output statements. 4100U Custom Control uses the following logical operators.

- **AND Operator.** The AND logical operator allows you to put a group of points in series so that only the activation of **all points at the same time** causes the Output side of the equation to occur. In the following example, Zone1 and Zone2 must both be in alarm (FIRE) before the output (Hold ON SIG3) executes.

```
[INPUTS]
STATUS FIRE
  ZN1 | MONB | FIRE | MONITOR CARD 3 ZONE ZN1
AND STATUS FIRE
  ZN2 | MONB | FIRE | MONITOR CARD 3 ZONE ZN2
[END INPUTS]
[OUTPUTS]
HOLD ON PRI=9.9
  SIG3 | SIGB | SSIGNAL | SIGNAL CARD 1 CIRCUIT SIG3
[END OUTPUTS]
```

- **OR Operator.** The OR operator allows you to put a group of points in parallel, *meaning the activation of **any** one or more of the points causes the output side of the equation to execute.* In the following example, if Zone1 **or** Zone2 enters an alarm state, the output (Hold ON SIG3) executes.

```
[INPUTS]
  STATUS FIRE
    ZN1 | MONB | FIRE | MONITOR CARD 3 ZONE ZN1
  OR STATUS FIRE
    ZN2 | MONB | FIRE | MONITOR CARD 3 ZONE ZN2
[END INPUTS]
[OUTPUTS]
  HOLD ON PRI=9.9
    SIG3 | SIGB | SSIGNAL | SIGNAL CARD 1 CIRCUIT SIG3
[END OUTPUTS]
```

- **NOT Operator.** Use the NOT Operator to specify that a condition must not be true in order for the output to execute. In the following example, the output side of the equation (print message "Smoke not dirty") executes only if the condition of M1-1 is NOT dirty.

```
[INPUTS]
  NOT STATUS DIRTY
    M1-1 | PHOTO | SMOKE | LAB1-SMOKE1
[END INPUTS]
[OUTPUTS]
  PRINT ALL "SMOKE NOT DIRTY"
[END OUTPUTS]
```

Selecting the Custom Control tab from the main programmer window displays the Custom Control Window. This window contains two halves:

- The left half lists user-defined and system-only (non-editable) equations. Click on the + sign to the left of an entry to expand the contents of that entry.
- The right half of the window is used for creating user-defined Custom Control equations. The Equation Comment text entry box allows you to enter descriptive text explaining the operation of the equation. The Equations Area contains a text entry box for creating and editing an equation's input and output statements. The **Add...** Button starts the Custom Control Wizard and is used to create new equations. The **Edit...** Button is used to edit existing equations. The **Taglist...** Button starts a taglist that can be used for selecting/deselecting points in an existing equation.

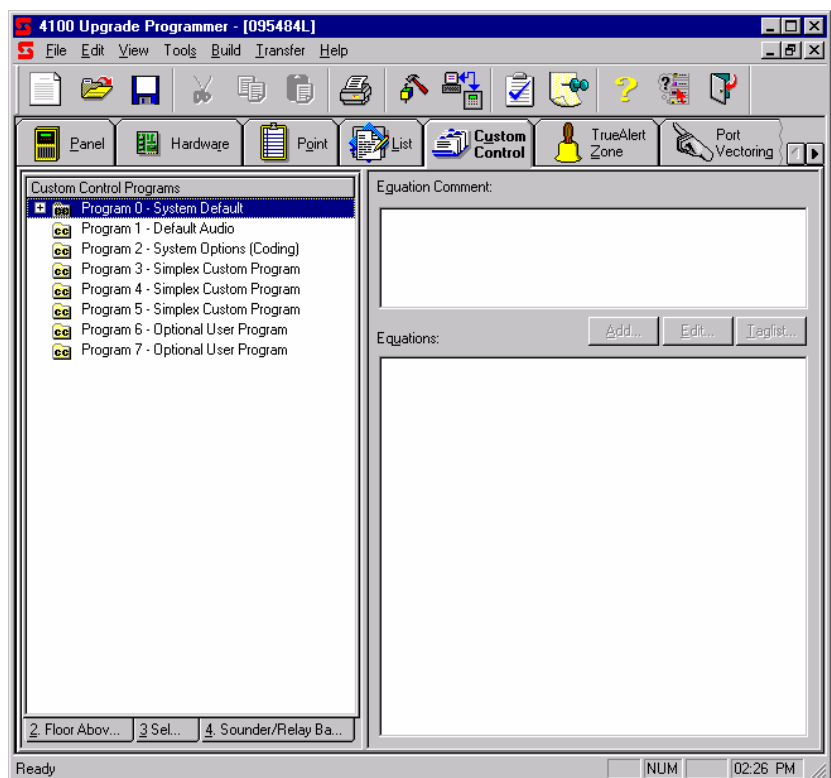

9.3 Creating a New Equation

9.3.1 Select User Program

The first step in defining a new custom control equation is to add the equation to either one of the five User Programs -- Program 3 through Program 7. However, it is recommended that Program 6 is used for general functions and Program 7 is used for AS1668 Fan Controls. Follow these steps to do this.

1. Right click on one of the user programs (Program 3 through Program 7), located at the bottom of the program list, and select **Add Equation...** from the list of options.

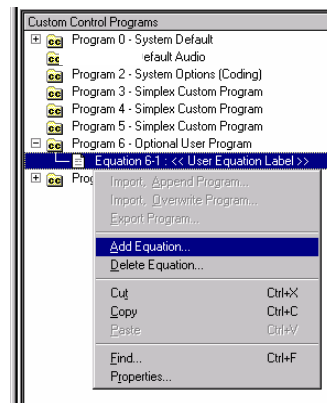

2. The properties dialog shown below appears. Enter a name for the equation in the **Label:** text box and click on **OK**.

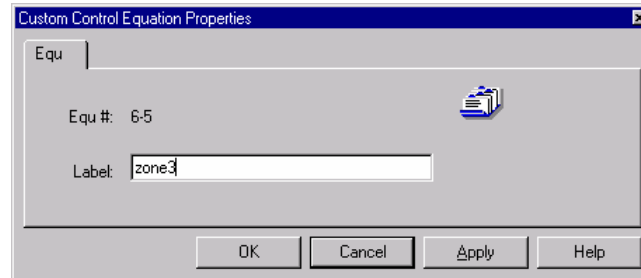

The Equations section of the Custom Control window updates to include the **[INPUTS]**, **[END INPUTS]**, etc entries.

9.3.2 Add Input Statements

The second step in creating a new Custom Control equation is to add input statements to the equation. Repeat the steps in this section until all input statements in the equation have been defined.

1. In the Equations box, position the cursor just to the right of **[INPUTS]**.

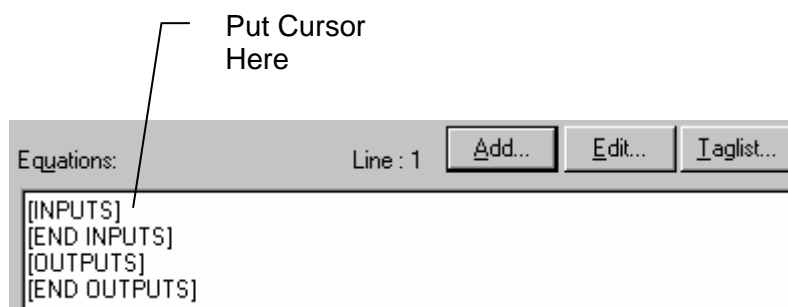

2. Click on the **Add** button. The dialog shown below appears.



3. Click on the drop down list box, select one of the Opcodes, and click the **Next** button.
4. The next dialogs displayed by the wizard depend on the Opcode you selected in Step 3.
5. The **Finish** button becomes available when all dialogs related to the input opcode have appeared. Click it to finish defining the input statement.

9.3.3 Add Output Statements

The third step in creating a new Custom Control equation is to add output statements to the new equation. Repeat the steps in this section until all output statements in the equation have been defined.

1. In the Equations box, position the cursor just to the right of **[OUTPUTS]**

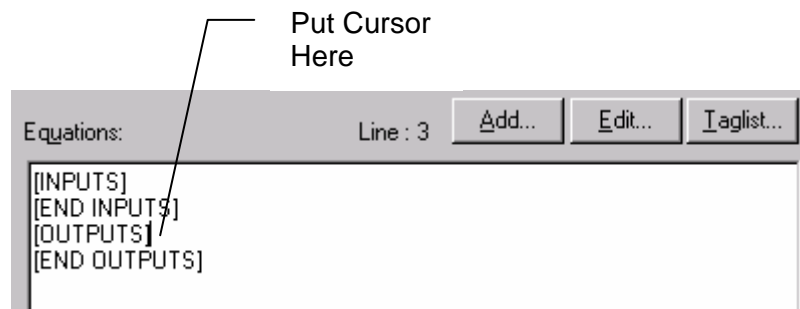

2. Click on the **Add** button. The dialog shown below appears.



3. Click on the drop down list box, select one of the output Opcodes, and click the **Next** button.
4. The next dialogs displayed by the wizard depend on the Opcode you selected in Step 3.
5. The **Finish** button becomes available when all dialogs related to the output opcode have appeared. Click it to finish defining the output statement.

THIS PAGE IS INTENTIONALLY BLANK

10 AS1668 Fan Controls

10.1 Typical Arrangement For AS1668 Fan Control

The following scheme illustrates a typical topology using the AS1668 Fan Control Module.

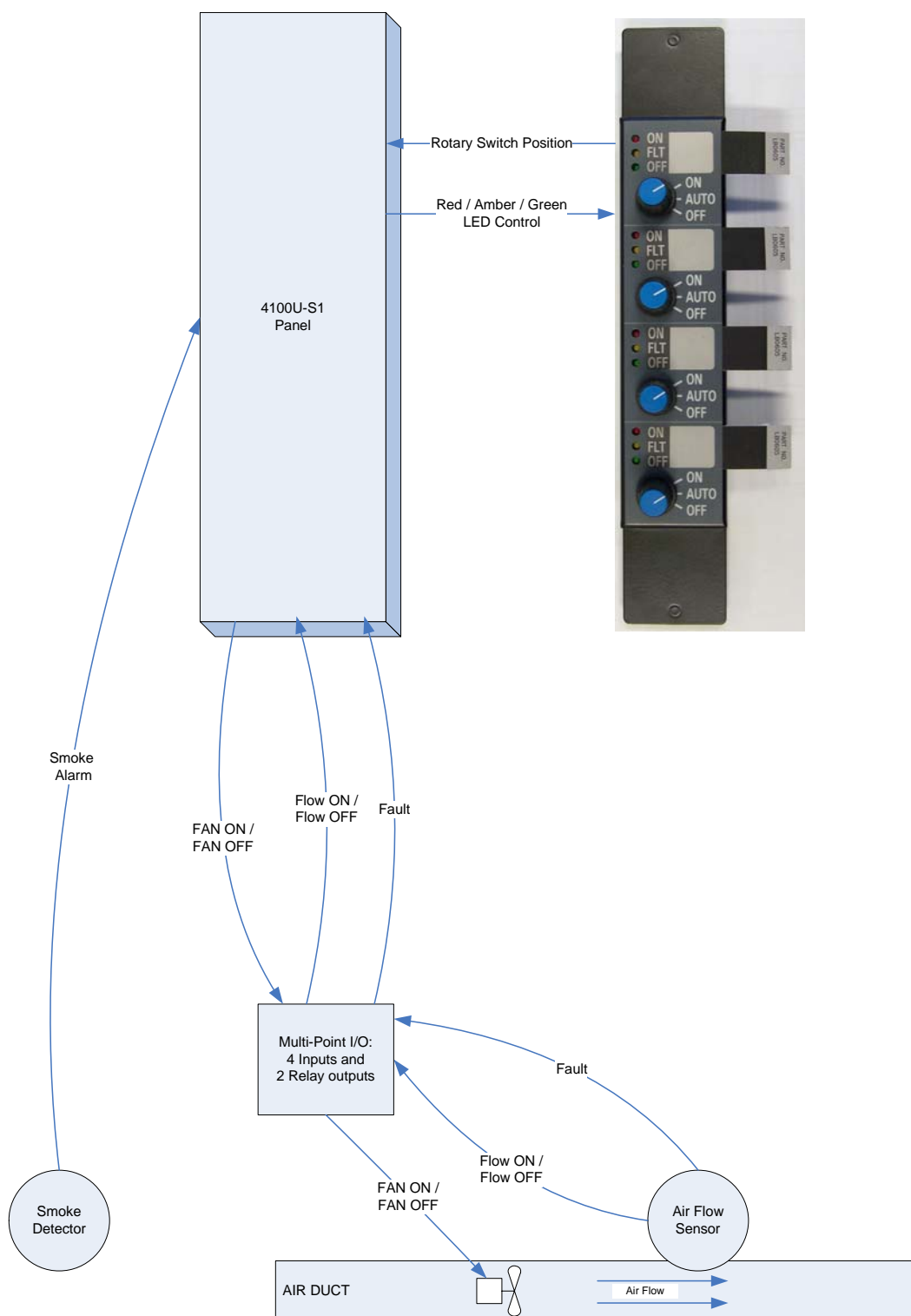

10.2 AS1668 Fan Control Flows

The control of ventilation and air conditioning in buildings under fire mode is described in AS/NZS 1668.1:1998. This requires fire alarm detection to activate the fan to prevent the smoke from spreading to other zones. In another topology - when fire is detected it is required to stop the fan to prevent smoke spreading to other areas of the building.

The following fan control example describes the situation where on fire detection it is desired to activate the fan to spill the smoky air outside.

Fan Activate in AS1668 Auto Position:

1. The 4100U-S1 panel receives indications of smoke alarm from detectors on its loop.
2. The 4100U-S1 panel sends to the Multi-Point I/O a control to close the relay that controls the fan to start.
3. The Multi-Point I/O closes the relay to start the fan.
4. The fan runs, and air flows through the duct.
5. An air flow sensor in the duct sends to the panel via the Multi-Point I/O an indication that the air is flowing.
6. The panel controls the AS1668 module to turn the Red "ON" LED to ON and the Green "OFF" LED to OFF.

Fan Stop in AS1668 Auto Position:

1. The 4100U-S1 panel receives indication of smoke alarm clearing from the detectors on its loop.
2. The 4100U-S1 panel commands the Multi-Point I/O to open the relay that controls the fan.
3. The Multi-Point I/O opens the relay to stop the fan.
4. The fan stops and air does not flow through the duct.
5. An air flow sensor in the duct sends to the panel via the Multi-Point I/O an indication that the air flow is OFF.
6. The panel controls the AS1668 module to turn the Green "OFF" LED to ON and the Red "ON" LED to OFF.

AS1668 Fan Manual Start:

1. The 4100U-S1 panel receives indication from its AS1668 board that Fan #1 rotary switch state has changed to 'Start'.
2. The 4100U-S1 panel commands the Multi-Point I/O to close the relay that controls the fan.
3. The Multi-Point I/O closes the relay to start the fan.
4. The fan runs and air flows through the duct.
5. An air flow sensor in the duct sends to the panel via the Multi-Point I/O an indication that the air flow is ON.
6. The panel controls the AS1668 to turn the Red "ON" LED to ON and the Green "OFF" LED to OFF.

AS1668 Fan Manual Stop:

1. The 4100U-S1 panel receives indications from its AS1668 board that Fan #1 rotary switch state has changed to 'Stop'.
2. The 4100U-S1 panel commands the Multi-Point I/O to open the relay that controls the fan to stop.
3. The Multi-Point I/O opens the relay to stop the fan.
4. The fan stops and air does not flow through the duct.
5. An air flow sensor in the duct sends to the panel via the Multi-Point I/O an indication that the air flow is OFF.
6. The panel controls the AS1668 to turn the Green "OFF" LED to ON and the Red "ON" LED to OFF.

AS1668 Fan Fault:

1. The fan controller sends a fault (e.g. mains failure) to the Multi-Point I/O (as an open circuit).
2. The Multi-Point I/O sends to the panel a fault condition.
3. The panel controls the AS1668 module to turn the amber "FLT" LED to ON.

AS1668 Fan Start Failure:

1. The 4100U-S1 panel sends to the Multi-Point I/O a control to close the relay that controls the fan to start (e.g. as result of Manual start or auto start).
2. The air flow sensor in the duct **does not** send to the panel an indication that the air flow is ON.
3. The panel controls the AS1668 to turn the amber Fault LED to ON.

AS1668 Fan Stop Failure:

1. The 4100U-S1 panel sends to the Multi-Point I/O a control to open the relay that controls the fan to stop.
2. The air flow sensor in the duct **does not** send to the panel an indication via the Multi-Point I/O that the air flow is OFF.
3. The panel controls the AS1668 to turn the Amber Fault LED to ON.

10.3 AS1668 Fan Control State Table

The following table shows how the airflow input is reflected on the AS1668 red and green LEDs.

Airflow Input	AS1668 Green & Red LEDs
ON	Red ON Green OFF
OFF	Green ON Red OFF

The following table summarises the AS1668 amber (Fault) LED operation.

AS1668 Rotary Switch State	Airflow Input	Fault Input	AS1668 Amber LED
START	ON	OFF	Amber OFF
START	OFF	Don't care	Amber ON
STOP	OFF	OFF	Amber OFF
STOP	ON	Don't care	Amber ON
Don't care	Don't care	ON	Amber ON

10.4 AS1668 Fan Control Card Programming

The 4100U-S1 can be installed with an ME0456 AS1668 fan control module which is programmed as a 4100-1282 8 x Button 16 Red-Yellow LED module.

Follow the 4100-1282 programming as described in Section 7.3, except for the **Point Editing** tab which differs from the standard zone programming and is described here.

10.4.1 Switch Configuration

The **Switch** configuration couples each of the fans' rotary switch states to a pseudo point that reflects the current fan state. The fans' pseudo points definition is built-in as part of the configuration template. These pseudo points can be monitored via the panel's display screen and referred to from the online executable via custom controls.

Each fan uses 2 X **Switch** entries with a pseudo point for each entry that is set whenever the entry state is reached:

1. In 'Manual Start' state –The 'Manual Start' pseudo point is set and the 'Manual Stop' pseudo point is cleared.
 2. In 'Manual Stop' state –The 'Manual Stop' pseudo point is set and the 'Manual Start' pseudo point is cleared.
- When in 'Auto' position both the 'Manual Start' and the 'Manual Stop' pseudo points are cleared.

- In the **Mode** text box enter 'PBT'.
- In the **Reference Address** text box enter the matching pseudo point (P1201 - P1216).
- Highlight the next line to configure the next entry with the adjacent pseudo point.

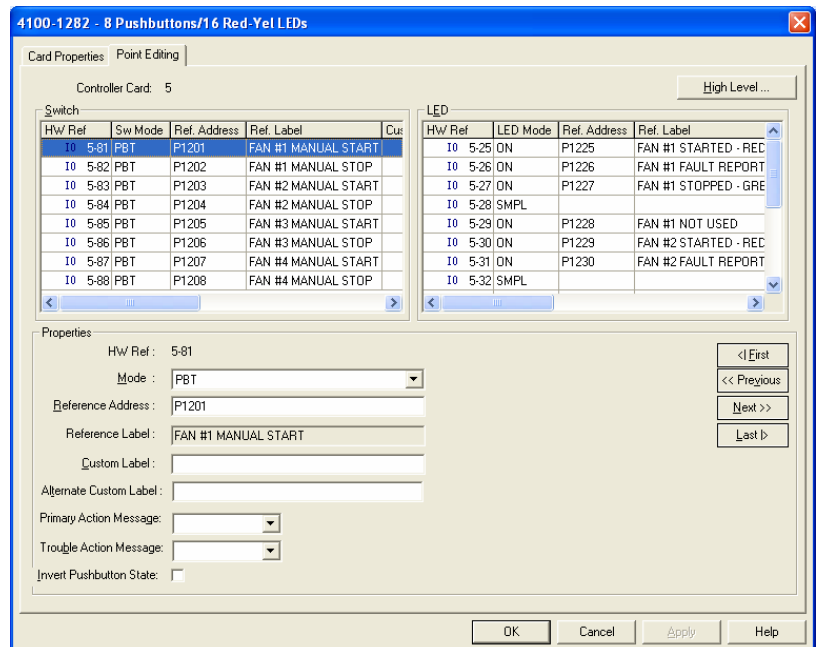

10.4.2 LED Configuration

The LEDs configuration couples the Red Amber and Green LEDs of each fan to a pseudo point.

Each fan uses 4 LEDs:

LED 1 set = Red LED is ON = Fan is running.

LED 2 set = Amber LED is ON = Fan is faulty.

LED 3 set = Green LED is ON = Fan is not running.

LED 4 is not used.

These pseudo points can be monitored via the panel's display screen and referred to from the online executable via custom controls.

- In the **Mode** text box enter 'ON'.
- In the **Reference Address** text box enter the matching pseudo point (starting at P1225).
- Highlight the next line to configure the next entry with the adjacent pseudo point.
- Every 4th line (the 4th entry of each fan) should be left as SMPL and without a pseudo point configured.

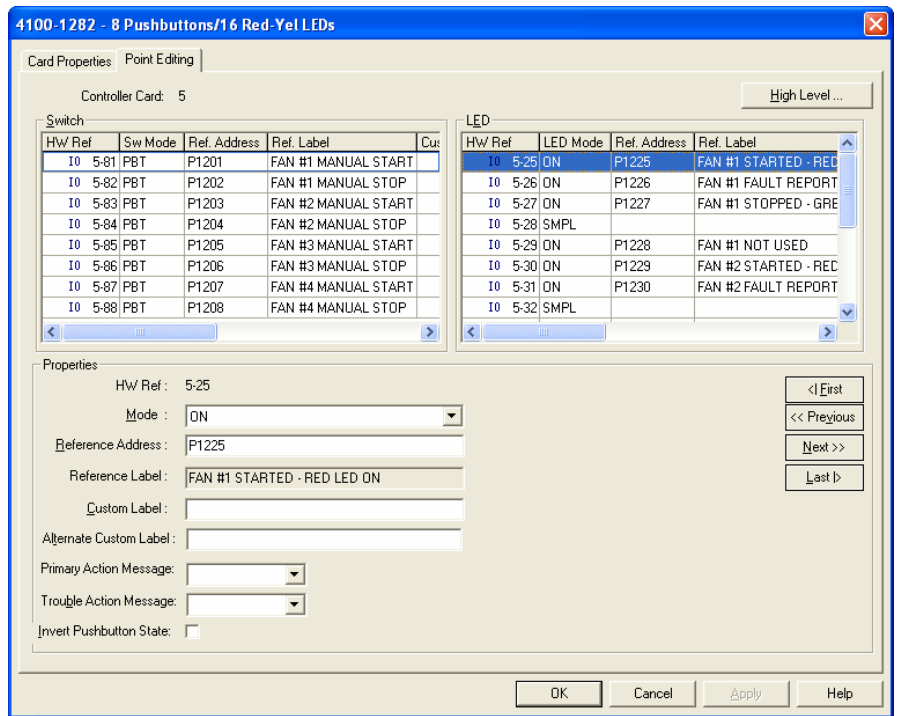

When all the configured fans have pseudo points for the **Switch** and **LED** – click OK.

10.4.3 Point Editing

Click the **Point** tab and scroll to point P1225 which is coupled to the red LED of the 1st fan. Configure the points as described hereafter for the 1st fan:

Click on the line and select for the **Point Type** *UTILITY*.

In the **Custom Label** text box enter a related meaningful text e.g. *FAN #1 ON = RED LED*.

Click the **Next>>** button, Select for the **Point Type** *TBL (trouble)*

In the **Custom Label** text box enter a related meaningful text e.g. *FAN #1 FAULT = AMBER LED*.

Click the **Next>>** button, Select for the **Point Type** *UTILITY*.

In the **Custom Label** text box enter a related meaningful text e.g. *FAN #1 OFF = GREEN LED*.

Click the **Next>>** button, This line is the fan's 4th entry and is reserved. In the **Custom Label** text box enter a related meaningful text e.g. *FAN #1 NOT USED*.

Continue editing the points of the rest of the configured fans in the same way.

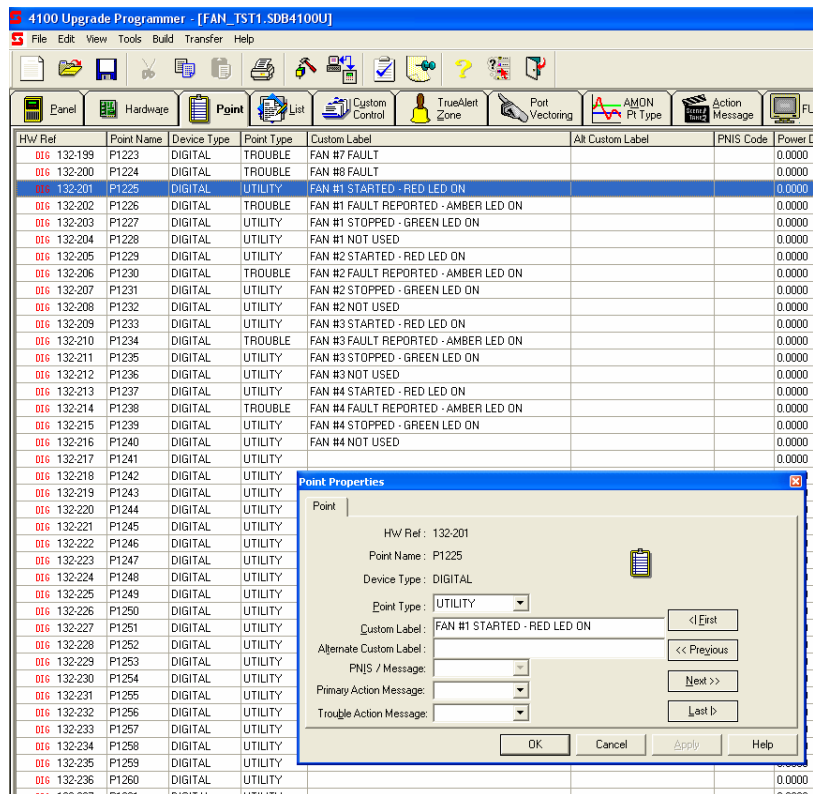

10.5 AS1668 Custom Control Equations

The control implementation of the AS1668 fans and the AS1668 LEDs as described in 10.3 is done using custom controls that should be included in the custom control Program 7: AS1668 FAN CONTROL CUSTOM CONTROL.

The following is an example of 8 custom controls to control fan #1. In this example - the fan is controlled by point M1-18-6 which is an output relay on a Multipoint I/O module (4090-9120AU 6 point I/O Module – 4 Inputs, 2 Relay outputs). The airflow status and fan fault are inputs on the M1-18-1.

10.6 AS1668 Custom Control Equations

The control of the fans and the AS1668 LEDs as described in **Error! Reference source not found.** is done using custom controls that evaluate the custom control program 7: AS1668 FAN CONTROL CUSTOM CONTROL.

The following is an example of required custom control equations to control fan #1. In this example - the fan is controlled by point M1-18-6 which is an output relay on Multipoint I/O module (4090-9120AU 6 point I/O Module – 4 Inputs, 2 Relay outputs). The airflow status and the fan fault are inputs on M1-18-1 and M1-18-2 respectively.

10.6.1 [EQUATION] | 1 Toggle FAN -> Toggle RED & Green LEDs

This equation sets the red LED to ON and the green LED to OFF when the airflow indicator input is ON and sets the red LED to OFF and the green LED to ON when the airflow indicator input is OFF.

```
[INPUTS]
    STATUS ON
        M1-18-1 | | UTILITY | FAN1 AIRFLOW INDICATOR
[END INPUTS]

[OUTPUTS]
    TRACK ON PRI=9,9
        P1225 | | UTILITY | FAN #1 STARTED - RED LED ON
    TRACK OFF PRI=9,9
        P1227 | | UTILITY | FAN #1 STOPPED - GREEN LED ON
[END OUTPUTS]

[END EQUATION]
```

10.6.2 [EQUATION] | 2 Trigger FAN ON

This equation sets the fan control relay to operate the fan when smoke alarm on detector M1-2-1 (can be replaced with any other trigger e.g. any smoke alarm defined by a list) is ON, or when the 'manual-start' is operated.

```
[INPUTS]
    STATUS ON
        M1-2-1 | | SMOKE |
    OR STATUS ON
        P1201 | | UTILITY | FAN #1 MANUAL START
[END INPUTS]

[OUTPUTS]
    TRACK ON PRI=9,9
        M1-18-6 | | CEXHAUS | FAN CONTROL
[END OUTPUTS]

[END EQUATION]
```

10.6.3 [EQUATION] | 3 Trigger FAN OFF

This equation sets the fan control relay to operate the fan when smoke alarm is OFF and the manual-start is off, or when the manual-stop is ON.

```
[INPUTS]
  NOT STATUS ON
    M1-2-2 | | HEAT |
  AND NOT STATUS ON
    P1201 | | UTILITY | FAN #1 MANUAL START
  SAVE 1
  RECALL 1
  OR STATUS ON
    P1202 | | UTILITY | FAN #1 MANUAL STOP
[END INPUTS]

[OUTPUTS]
  TRACK OFF PRI=9,9
    M1-18-6 | | CEXHAUS | FAN CONTROL

[END OUTPUTS]

[END EQUATION]
```

10.6.4 [EQUATION] | 4 FAN 1 triggered but no airflow -> fault

This equation sets the amber LED (fault) to ON when the fan control relay is set to operate the fan but the airflow indicator does not report that air is flowing, and the AS1668 fan switch state is 'manual start'. (When AS1668 fan switch state is 'Auto' and when not in 'Fire mode' then the alarm should not be triggered).

```
[INPUTS]
  STATUS ON
    M1-18-6 | | CEXHAUS | FAN CONTROL
  AND NOT STATUS ON
    M1-18-1 | | UTILITY | FAN1 AIRFLOW INDICATOR
  AND STATUS ON
    P1201 | | UTILITY | FAN #1 MANUAL START

[END INPUTS]

[OUTPUTS]
  TRACK ON PRI=9,9
    P1226 | | TROUBLE | FAN #1 FAULT REPORTED - AMBER LED ON

[END OUTPUTS]

[END EQUATION]
```

10.6.5 [EQUATION] | 5 FAN 1 stopped but airflow runs -> fault

This equation sets the amber LED (fault) to ON when the fan control relay is set to stop the fan but the airflow indicator still indicates that air is flowing, and the AS1668 fan switch state is 'manual stop'. (No fault when AS1668 fan switch state is 'Auto').

```
[INPUTS]
    NOT STATUS ON
      M1-18-6 | | CEXHAUS | FAN CONTROL
    AND STATUS ON
      M1-18-1 | | UTILITY | FAN1 AIRFLOW
    AND STATUS ON
      P1202 | | UTILITY | FAN #1 MANUAL STOP

[END INPUTS]

[OUTPUTS]
    TRACK ON PRI=9,9
      P1226 | | TROUBLE | FAN #1 FAULT REPORTED - AMBER LED ON

[END OUTPUTS]

[END EQUATION]
```

10.6.6 [EQUATION] | 6 FAN 1 FAULT Report ON

This equation sets the amber LED (fault) to ON when the 'fan fault' relay is reporting fault, and to OFF when there is no fault (using the 'TRACK' opcode takes care to clear the amber LED when no fault input).

```
[INPUTS]
    STATUS TBL
      M1-18-2 | | UTILITY | FAN1 FAULT INDICATOR

[END INPUTS]

[OUTPUTS]
    TRACK ON PRI=9,9
      P1226 | | TROUBLE | FAN #1 FAULT REPORTED - AMBER LED ON

[END OUTPUTS]

[END EQUATION]

[END PROGRAM]
```

THIS PAGE IS INTENTIONALLY BLANK

11 Building & Downloading the Configuration

11.1 General

When you are finished programming a job, you must first build the job before downloading it. Building a job takes the .SDB file (the un-compiled, “working” file) and creates a CFG file (compiled version of job, usable by panel) that can be downloaded to the panel.

If errors are detected by the build operation, they are flagged and the build operation aborts. These errors must be resolved before the build can be performed and the CFG can be created. Contact Simplex Service Support for help in resolving build errors.

1. Start the programmer and open the job that you want to build.
2. Start the build utility, by clicking on the **Build** menu and selecting the **Build** menu option.

3. When the **Revision History** dialog appears, enter the name of the job in the **Name** field (or the name of the person making the changes). Enter the modifications made to the job in the **Enter Modifications** text box. Click OK.

The 4100U Job Builder dialog appears. It contains messages, including errors, related to the creation of the downloadable CFG file.

4. If the dialog says “**Build Complete**,” you are ready to download the file to the panel. If error messages appear, along with a “**Build Aborted**” message, you must first resolve the errors before rebuilding the job.

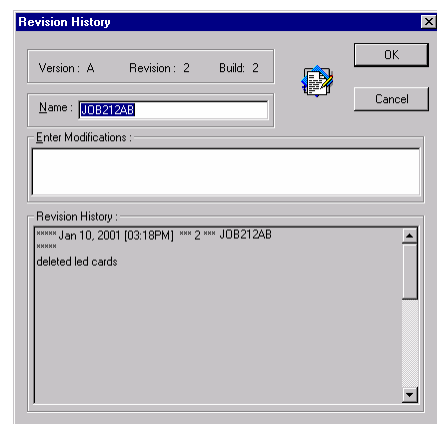

11.2 Starting the Transfer Utility

The 4100U **File Transfer** utility can be started from within the 4100U Programmer or from the Windows **Start** menu:

- From within the 4100U Programmer: If the programmer is already running, click on the **Transfer** menu, located along the menu bar at the top of the programmer window. When the options appear, click on **Transfer**.
- From the Windows **Start** Menu: Click the Start button. Move the pointer to the Programs option. When the list of choices appears, move the pointer to the **Simplex** option and click on the option containing the appropriate programmer (for example, **4100U Ver 11.01.01**). A list of options appears. Click on **File Transfer**.

In both cases, the **File Transfer** utility is launched.

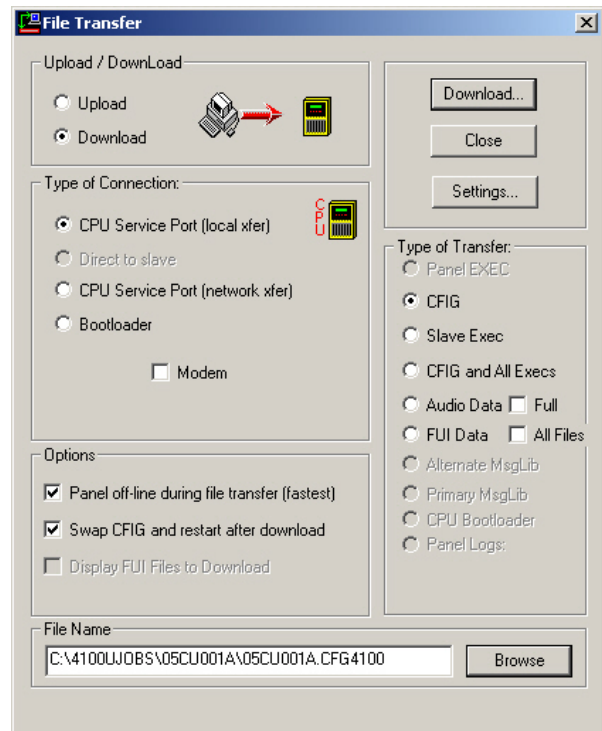

11.3 Serial Communication Parameter Settings

Clicking the **Settings...** button allows you to set the serial port, baud rate, parity, and stop bits used by the PC. In most cases (see note below), it is recommended that you use the default settings for these parameters.

Note: If you connect the serial cable (733-794) to a port other than COM1, make sure to open the Port Settings dialog and change the default (COM1) to the port being used.

In the **File Transfer** utility screen, click on the **Settings...** button. A window similar to the following appears. This window allows you to specify the settings for the serial communication parameters used by the PC.

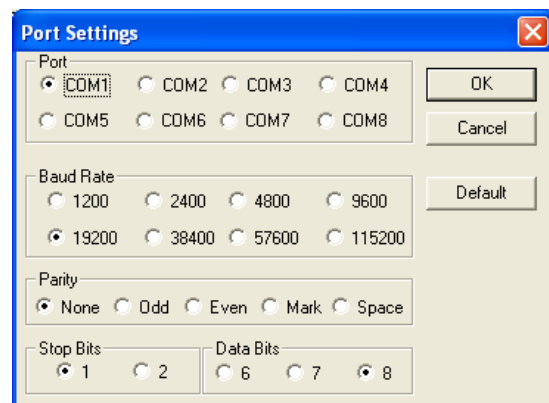

11.4 Direct Connection to the Panel

Follow these steps to connect the 733-794 serial cable between the PC and the panel.

1. Locate the PC within 6 feet of the panel and connect a 733-794 serial cable to the configured serial port (typically COM1) on the PC.
2. Connect the other end of the cable to the service port on the front panel of the 4100U, to the left of the operator interface. For 2 X 40 displays, make sure the red stripe is aligned to the left as you connect the cable. For InfoAlarm displays, make sure the red stripe is aligned to the bottom as you connect the cable.



3. Run the **File Transfer** utility and select the **CPU Service Port (local xfer)** radio button.

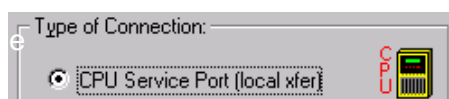

11.5 Downloading the CFG File

1. Set the **Download** radio button.
2. Set the **Type of Connection** to CPU Service (local xfer) and connect the PC's serial port to the panel's service port.
3. Click on the CFG radio button in the **Type of Transfer** area.
4. Set the **Options** to use during the download.
 - **Panel Off-Line During File Transfer (Fastest)** - Select this option when downloading a large job (thousands of points, complicated custom control equations). Note that the panel is non-functional for the duration of the download when this option is selected.
 - **Swap CFG and restart after download** - In most cases, this option should be selected. When selected, the existing CFG is automatically replaced with the CFG being downloaded and the panel is automatically restarted following download.
5. Click the **Browse** button and use the standard Windows dialog to open the folder containing the built job file (.CFG4100U). When the folder containing the CFG is open, click on the filename and click Open to select the file and close the dialog box.

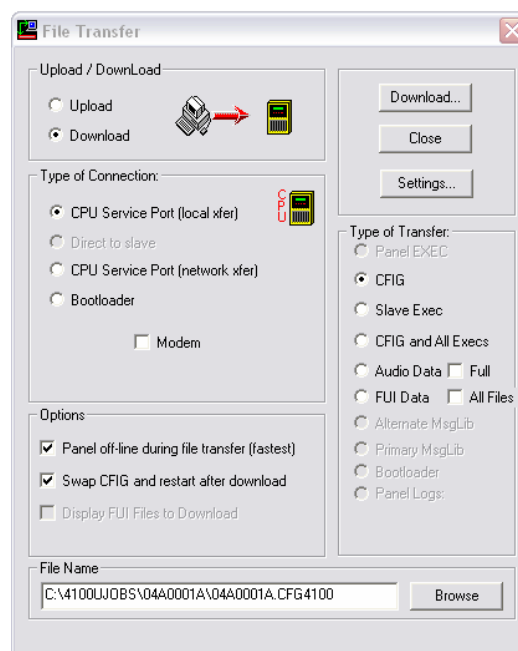

6. Click the **Download...** button. A dialog as follow appears:

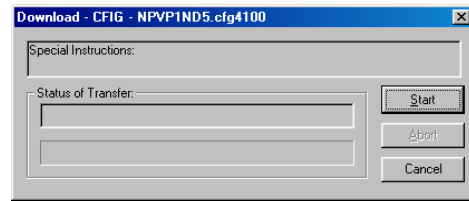

7. Click the **Start** button to begin the download. The display on the front panel of the 4100U shows the progress of the download, and notifies when the download is complete.
8. At the end of download the panel restarts automatically on the configuration.
9. The panel running the new configuration requires to adjust its date and time via the panel display menu.

THIS PAGE IS INTENTIONALLY BLANK

12 Appendices

12.1 Appendix A – AS4428.1 Operation

A 4100U-S1 is required to comply to AS 4428.1 needs special functionality to be implemented. This is done by a number of custom control equations.

Program 3 contains the system functions to provide brigade relay operation, common front panel controls, battery testing and AVF Program 4 contains the functions to operate the zone alarm and fault LEDs and to use the Isolate pushbutton to isolate/de-isolate the zone or general alarm/fault tests.

These programs should not be changed, except for removing unneeded zone equations in Program 4, or adding zone equations when more zones are added.

Details of these programs are contained in the following sections.

12.2 Appendix B - Common Variables and Custom Control

The following explains Points and Lists that are used in the AS 4428.1 Custom Control Logic. These Points and Lists may also be used in other custom control equations not listed below.

In the following sections the equation number is shown on the title line of the equation. For example, 3-8 Battery Test.

12.2.1 Digital Points

Digital Points can be ON or OFF.

P0 – System Reset Key

Used in Equation 3-16 to Reset Alarm & Fault Test Lists

P11 – Unacknowledged device Alarm exists

Used in Equation 3-9 to make Common Alarm LED flash on Unacknowledged Alarm

P21 – Enable Program 5 – Alarm / Fault Tests

Used in Equation 3-7 to Turn OFF Alarm & Fault Test Code until required by Alarm / Fault Test Mode operation

Used in Equation 3-12 to enable code for Alarm Test operation

Used in Equation 3-14 to enable code for Fault Test operation

Used in Equation 3-15 to disable Alarm & Fault Test operation code after preset time delay

P204 – Signals Silenced

Used in equation 3-18 to disable the Alarm Silence LED on the Operator LCD

P210 – Network Detector Reset

Used in equation 3-16 to disable Alarm and Fault Tests when a Network Reset is initiated.

P212 – Detector/ System Reset

Used in equation 3-16 to disable Alarm and Fault Tests when a Local Reset is initiated.

P512 – An unacknowledged Zone Alarm Exists

Used in equation 3-9 to flash the Common Alarm LED

Used in equation 3-10 to set the Common Alarm LED to steady

Turned on by each of the AZF Zones “New Alarm” equation

P513 – Alarm/Fault Test Button pressed

P514 – Alarm Test Active

P515 – Fault Test Active

P516 – Alarm or Fault Test Active

P517 – ACF Isolated

P518 – Bell Isolated

P519 – Warning System Isolated

P520 – Manual Battery Test

P521 – A/C Trip

P522 – A/C Reset

12.2.2 Analog Points

Analog Points can store a value 0-65535.

- A0 – Number of Devices in Alarm
- A1 – Number of Isolates
- A2 – Number of Faults
- A34 – System Startup pulse
- A257 – Alarm & Fault Test Timeout

12.2.3 Lists

Lists are used to group the status of several input points or control the status of several output points.

- L256 – Brigade call Alarm List
- L257 – General Fire Trip List (ACF Isolatable)
- L258 – Zone Alarm Test List
- L259 – Zone Fault Test List
- L260 – Zone Isolate Toggles

12.2.4 Physical Hardware Points (LEDs Relays etc)

Alarm Test Active LED or keyboard panel	(P514)
A/C Trip LED	(P521)
ACF Isolated LED	(P517)
Bells Isolated LED	(P518)
0-5-10	Warning System Isolated LED (P519)
0-5-11	Common Alarm LED
0-5-13	Fault Test Active LED (P515)
0-5-1	Alarm Fault Normal Button (P513)
0-5-2	A/C Reset Button (P522)
0-5-3	ACF Isolate Button (P517)
0-5-4	Bell Isolate Button (P518)
0-5-5	Warning System Isolate Button (P519)
0-7-3	City Alarm Relay
0-7-4	City Alarm Trouble Relay (FAULTS)
1-9	City Fire Relay 1 (ALARMS)
1-11	City Supervisory Relay 2 (ISOLATES)
1-12	City Trouble Relay 3 (FAULTS)
SIG3	ACF General Fire Trip (SPS NAC 1)
SIG4	Fire Alarm Bell (SPS NAC 2)
SIG5	Warning System (SPS NAC 3)

12.2.5 Battery Test

The battery is automatically tested at 8:00:03 every Tuesday morning according to the internal clock. The test runs for 1 hour.

The battery test is disabled if any Alarm is present or an Alarm occurs during the battery test. Manual battery tests can be started by activating P520.

References:

Point Address: 1-10 Battery Test Point
A256 Battery Test Timer
P520 Manual Battery Test

Equations:

3-8 Battery Test

[INPUTS]

```

WHEN DAY IS TUE
AND IF ANALOG = CONSTANT 8 CNTS
    A6 | Compare Analog | ANALOG | ANALOG | CURRENT HOUR
AND IF ANALOG = CONSTANT 0 CNTS
    A7 | Compare Analog | ANALOG | ANALOG | CURRENT MINUTE
AND IF ANALOG <= CONSTANT 3 CNTS
    A8 | Compare Analog | ANALOG | ANALOG | CURRENT SECOND
OR STATUS ON
    P520 | DIGITAL | UTILITY | MANUAL BATTERY TEST CONTROL
AND NOT STATUS ON
    L257 | LIST | DPSEUDO | GENERAL FIRE TRIP LIST (ACF ISOLATABLE)
DELAY CONSTANT 3605
    A256 | Analog Timer | ANALOG | TIMER | BATTERY TEST TIMER
SAVE 1
IF ANALOG > CONSTANT 0 CNTS
    A256 | Compare Analog | ANALOG | TIMER | BATTERY TEST TIMER
AND NOT STATUS ON
    A256 | ANALOG | TIMER | BATTERY TEST TIMER

```

[END INPUTS]

[OUTPUTS]

```

TRACK ON PRI=8,8
    1-10 | SPECOUT | SPECOUT | CITY PRI2
TRACK ON PRI=9,9
    P520 | DIGITAL | UTILITY | MANUAL BATTERY TEST CONTROL

```

[END OUTPUTS]

12.2.6 Alarm Verification Timing and Start Up settings

This equation is used to set any default settings when the panel is powered up or has been restarted by CPU hardware reset button.

References:

Point Address:
A34 System Start up Pulse timer
A37 AVF Retard Time
A38 AVF Reset Time
A39 AVF Confirmation Time
P21 Disable Program 5 Custom Control for Alarm & Fault Test

Equations:

3-7 Alarm Verification Timing / Start up

[INPUTS]

```

STATUS ON
    A34 | ANALOG | TIMER | SYSTEM STARTUP PULSE TIMER

```

[END INPUTS]

[OUTPUTS]

```

SET CONSTANT 5 CNTS
    A37 | Set-Analog (Destination) | ANALOG | ANALOG | ALARM VERIFICATION - RETARD TIME
SET CONSTANT 10 CNTS
    A38 | Set-Analog (Destination) | ANALOG | ANALOG | ALARM VERIFICATION - RESET TIME
SET CONSTANT 180 CNTS
    A39 | Set-Analog (Destination) | ANALOG | ANALOG | ALARM VERIFICATION - CONFIRMATION TIME

```

```
HOLD OFF PRI=7,7
P21 | DIGITAL | UTILITY | SMPL PROGRAM 5 - USER CUSTOM CONTROL
[END OUTPUTS]
```

12.2.7 Brigade Relay Equations

The following are the equations used to drive the Alarm, Isolate and Fault Brigade Relays. **These equations should not be modified without consulting a Simplex Technician.**

References:

Point Address:

0-7-3 City Alarm Relay (relay on 4100+ type CPU motherboard)
0-7-4 City Trouble Relay (relay on 4100+ type CPU motherboard)
1-9 City Fire/Opt Relay 1 (Alarm relay on SPS piggyback board)
1-11 City SUPV/Opt Relay 2 (Supervisory / Isolate relay on SPS piggyback board)
1-12 City Fire/Opt Relay 3 (Trouble relay on SPS piggyback board)
A1 Number of Isolates on Panel
A2 Number of Faults on Panel
L256 Brigade Call Alarm List

3-1 ASE Alarm Relay

```
[INPUTS]
STATUS ON
L256 | LIST | DPSEUDO | BRIGADE CALL ALARM LIST
[END INPUTS]
[OUTPUTS]
TRACK ON PRI=7,7
0-7-3 | MCODE7 | RELAY | Master Output - City Alarm Relay
TRACK ON PRI=7,7
1-9 | SPECOUT | SPECOUT | CITY FIRE/OPT RELAY 1
[END OUTPUTS]
```

3-2 ASE Isolate Relay

```
[INPUTS]
STATUS ON
A1 | ANALOG | ANALOG | NUMBER OF SYSTEM SUPERVISORIES
[END INPUTS]
[OUTPUTS]
TRACK ON PRI=7,7
1-11 | SPECOUT | SPECOUT | CITY SUPV/OPT RELAY 2
[END OUTPUTS]
```

3-3 ASE Fault Relay

```
[INPUTS]
STATUS ON
A2 | ANALOG | ANALOG | NUMBER OF SYSTEM TROUBLES
[END INPUTS]
[OUTPUTS]
TRACK ON PRI=7,7
0-7-4 | MCODE7 | RELAY | Master Output - City Trouble Relay
TRACK ON PRI=7,7
1-12 | SPECOUT | SPECOUT | CITY TBL/OPT RELAY 3
[END OUTPUTS]
```

12.3 Appendix C - Custom Control for Control Keys and Indicators

The main part of the Operator Interface (the several ACK keys, numeric keypad and LCD) has functionality which is controlled directly by the panel software, and cannot be re-configured.

The Control keys and Indicators at the left end of the Operator Interface provide functionality which is controlled by Custom Control equations to meet AS 4428.1 requirements.

These equations are part of Program 3. They should not be changed, except under the direction of Simplex Fire Products, since the operation of the panel may be adversely affected.

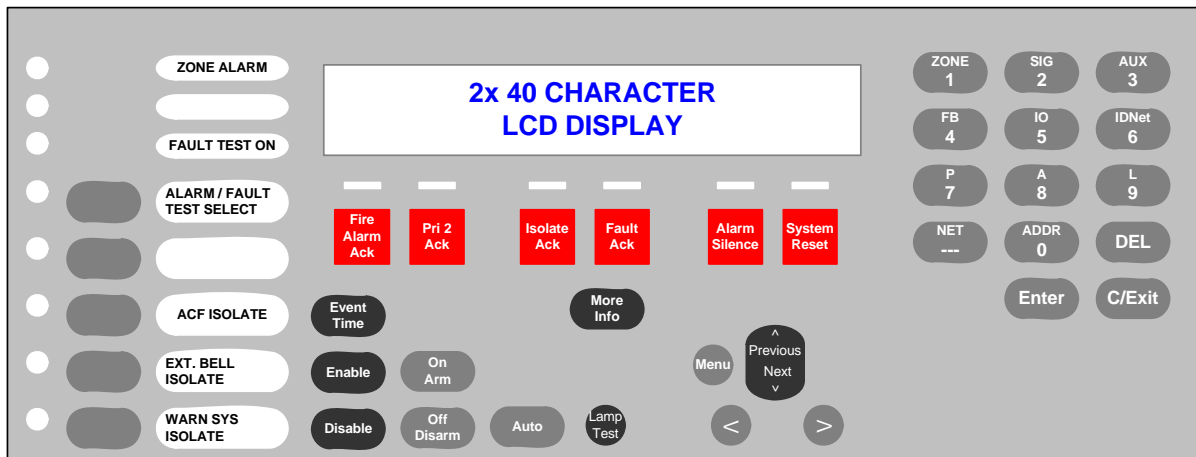

0-5-11 Common Alarm LED

0-5-13 Fault Test Active LED (P515)

0-5-6 Alarm Test Active LED (P514)

0-5-7 A/C Trip LED (P521)

0-5-8 ACF Isolated LED (P517)

0-5-9 Bells Isolated LED (P518)

0-5-10 Warning Sys Isolated LED (P519)

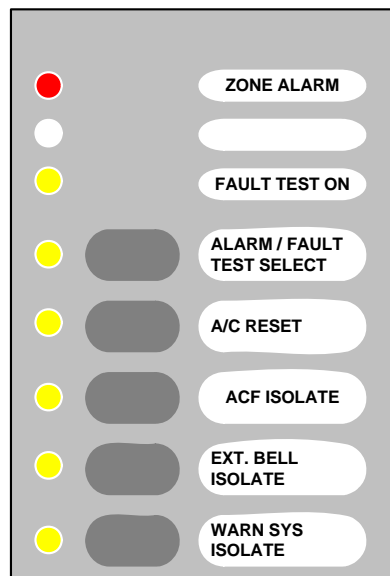

0-5-1 Alarm/Fault/Norm Button (P513)

0-5-2 A/C Reset Button (P522)

0-5-3 ACF Isolate Button (P517)

0-5-4 Bell Isolate Button (P518)

0-5-5 Warning Sys Isolate Button (P519)

12.3.1 Common Zone Alarm LED

This Red LED flashes if any Zone is in alarm and is not acknowledged.
The LED is on steady if any Zone is in Alarm and all Alarms are acknowledged.
The LED is off when there are no Zones in Alarm.

References

Point address: **0-5-11 Common Zone Alarm LED**

Equations:

3-9 Common Fire Alarm LED Flash

```
[INPUTS]
  STATUS ON
    P11 | DIGITAL | UTILITY | UNACKNOWLEDGED FIRE ALARM EXISTS
  AND STATUS ON
    L256 | LIST | DPSEUDO | BRIGADE CALL ALARM LIST
  AND STATUS ON
    P512 | DIGITAL | UTILITY | A ZONE ALARM LED IS FLASHING
[END INPUTS]
[OUTPUTS]
  FLASH SLOW
    0-5-11 | MKYLED5CRY | LEDRED | COMMON ALARM LED
[END OUTPUTS]
```

3-10 Common Fire Alarm LED Steady

```
[INPUTS]
  STATUS ON
    A0 | ANALOG | ANALOG | NUMBER OF SYSTEM FIRE ALARMS
  AND NOT STATUS ON
    P512 | DIGITAL | UTILITY | A ZONE ALARM LED IS FLASHING
[END INPUTS]
[OUTPUTS]
  FLASH ON
    0-5-11 | MKYLED5CRY | LEDRED | COMMON ALARM LED
[END OUTPUTS]
```

3-11 Common Fire Alarm LED Off

```
[INPUTS]
  NOT STATUS ON
    A0 | ANALOG | ANALOG | NUMBER OF SYSTEM FIRE ALARMS
[END INPUTS]
[OUTPUTS]
  FLASH OFF
    0-5-11 | MKYLED5CRY | LEDRED | COMMON ALARM LED
[END OUTPUTS]
```

12.3.2 Alarm / Fault / Normal Test Button & LEDs

This button is used to select between Alarm Test, Fault Test and Normal operation for the Multifunction buttons. The Alarm Test and Fault Test LEDs indicate what operation the Multifunction buttons will initiate if pressed.

The Alarm & Fault Test code is stored in a separate Program to all other code. This Program is enabled only if the panel is in Alarm or Fault Test mode.

References:

Push Button Mode	set to "PBH" Mode
Point Address:	0-5-1 Alarm Fault Test Normal (AFN) Button
P513	Status of AFN button
0-5-6	Alarm Test LED
P514	Active if panel is in Alarm Test Mode
0-5-13	Fault Test LED
P515	Active if panel is in Fault Test Mode

Equations:

3-12 Alarm Test Mode

```
[INPUTS]
STATUS ON
P513 | DIGITAL | UTILITY | ALARM TEST/FAULT TEST/NORMAL BUTTON
AND NOT STATUS ON
P514 | DIGITAL | UTILITY | ALARM TEST
AND NOT STATUS ON
P515 | DIGITAL | UTILITY | FAULT TEST
[END INPUTS]
[OUTPUTS]
HOLD ON PRI=9,9
P514 | DIGITAL | UTILITY | ALARM TEST
HOLD ON PRI=9,9
P516 | DIGITAL | UTILITY | ALARM OR FAULT TEST ACTIVE
HOLD OFF PRI=9,9
P513 | DIGITAL | UTILITY | ALARM TEST/FAULT TEST/NORMAL BUTTON
PRINT PANEL "ALARM TEST READY-PRESS FOR FAULT TEST"
HOLD ON PRI=7,7
P21 | DIGITAL | UTILITY | SMPL PROGRAM 5 - USER CUSTOM CONTROL
[END OUTPUTS]
```

3-13 Fault Test Mode

```
[INPUTS]
STATUS ON
P513 | DIGITAL | UTILITY | ALARM TEST/FAULT TEST/NORMAL BUTTON
AND STATUS ON
P514 | DIGITAL | UTILITY | ALARM TEST
AND NOT STATUS ON
P515 | DIGITAL | UTILITY | FAULT TEST
[END INPUTS]
[OUTPUTS]
HOLD ON PRI=9,9
P515 | DIGITAL | UTILITY | FAULT TEST
HOLD OFF PRI=9,9
P513 | DIGITAL | UTILITY | ALARM TEST/FAULT TEST/NORMAL BUTTON
HOLD OFF PRI=9,9
P514 | DIGITAL | UTILITY | ALARM TEST
PRINT PANEL "FAULT TEST READY-PRESS AGAIN FOR NORMAL"
[END OUTPUTS]
```

3-14 Alarm & Fault Test Mode OFF

```
[INPUTS]
  STATUS ON
    P513 | DIGITAL | UTILITY | ALARM TEST/FAULT TEST/NORMAL BUTTON
  AND STATUS ON
    P515 | DIGITAL | UTILITY | FAULT TEST
[END INPUTS]
[OUTPUTS]
  HOLD OFF PRI=9,9
    P515 | DIGITAL | UTILITY | FAULT TEST
  HOLD OFF PRI=9,9
    P516 | DIGITAL | UTILITY | ALARM OR FAULT TEST ACTIVE
  HOLD OFF PRI=9,9
    P513 | DIGITAL | UTILITY | ALARM TEST/FAULT TEST/NORMAL BUTTON
  PRINT PANEL "ALARM & FAULT TEST OFF"
  HOLD OFF PRI=7,7
    P21 | DIGITAL | UTILITY | SMPL PROGRAM 5 - USER CUSTOM CONTROL
[END OUTPUTS]
```

3-15 Alarm & Fault Test Timer

```
[INPUTS]
  STATUS ON
    P516 | DIGITAL | UTILITY | ALARM OR FAULT TEST ACTIVE
  AND NOT STATUS ON
    L258 | LIST | DPSEUDO | ALARM TEST LIST
  AND NOT STATUS ON
    L259 | LIST | DPSEUDO | FAULT TEST LIST
  DELAY CONSTANT 60
    A257 | Analog Timer | ANALOG | TIMER | ALARM & FAULT TEST TIMEOUT
[END INPUTS]
[OUTPUTS]
  HOLD OFF PRI=9,9
    P514 | DIGITAL | UTILITY | ALARM TEST
  HOLD OFF PRI=9,9
    P515 | DIGITAL | UTILITY | FAULT TEST
  HOLD OFF PRI=9,9
    P516 | DIGITAL | UTILITY | ALARM OR FAULT TEST ACTIVE
  HOLD OFF PRI=7,7
    P21 | DIGITAL | UTILITY | SMPL PROGRAM 5 - USER CUSTOM CONTROL
[END OUTPUTS]
```

3-16 Reset Alarm & Fault Test

```
INPUTS]
  STATUS ON
    L258 | LIST | DPSEUDO | ALARM TEST LIST
  AND NOT STATUS ON
    P514 | DIGITAL | UTILITY | ALARM TEST
  SAVE 1
  STATUS ON
    L259 | LIST | DPSEUDO | FAULT TEST LIST
  AND NOT STATUS ON
    P515 | DIGITAL | UTILITY | FAULT TEST
  OR RECALL 1
  OR STATUS ON
    P0 | DIGITAL | UTILITY | SYSTEM RESET KEY
  OR STATUS ON
    P210 | DIGITAL | UTILITY | NETWORK DETECTOR RESET
  OR STATUS ON
    P212 | DIGITAL | UTILITY | DETECTOR/SYSTEM RESET
[END INPUTS]
[OUTPUTS]
  HOLD OFF PRI=9,9
    L258 | LIST | DPSEUDO | ALARM TEST LIST
  HOLD OFF PRI=9,9
    L259 | LIST | DPSEUDO | FAULT TEST LIST
[END OUTPUTS]
```

Setup Register 8

```

[INPUTS]
  NOT STATUS ON
    P516 | DIGITAL | UTILITY | ALARM OR FAULT TEST ACTIVE
  SAVE 8
[END INPUTS]
[OUTPUTS]
[END OUTPUTS]

```

12.3.3 Example Alarm & Fault Test equations

These equations (with point number modifications) must be included for each zone to carry out the zone alarm or fault test when the zone button is pressed and alarm or fault test modes are active.

5-1 ZONE 1 Alarm Test

```

[INPUTS]
  STATUS ON
    P514 | DIGITAL | UTILITY | ALARM TEST
  AND STATUS ON
    P901 | DIGITAL | UTILITY | MULTIFUNCTION SWITCH - ZONE 1
[END INPUTS]
[OUTPUTS]
  HOLD ON PRI=9,9
    P1001 | DIGITAL | FIRE | ALARM TEST ZONE 1
[END OUTPUTS]

```

5-2 ZONE 1 Fault Test

```

[INPUTS]
  STATUS ON
    P515 | DIGITAL | UTILITY | FAULT TEST
  AND STATUS ON
    P901 | DIGITAL | UTILITY | MULTIFUNCTION SWITCH - ZONE 1
[END INPUTS]
[OUTPUTS]
  HOLD ON PRI=9,9
    P1101 | DIGITAL | TROUBLE | FAULT TEST ZONE 1
[END OUTPUTS]

```

12.3.4 A/C Reset Button & A/C Trip LED

The A/C Trip LED indicates that the Air Condition system Automatic control has activated. The A/C Reset button is used to disable the automatic control.

References

Push Button Mode set to "PBT" Mode

Point Address: **0-5-2 A/C Reset Button**
P522 A/C Reset Status

0-5-7 A/C Trip LED
P521 Status of A/C Trip

Equations:

3-17 A/C Trip Reset

```

[INPUTS]
  STATUS ON
    P522 | DIGITAL | UTILITY | A/C RESET
  AND NOT STATUS ON
    L257 | LIST | DPSEUDO | GENERAL FIRE TRIP LIST (ACF ISOLATABLE)
  OR STATUS ON
    P517 | DIGITAL | SUPERV | ACF ISOLATE
[END INPUTS]
[OUTPUTS]

```

```
HOLD OFF PRI=9,9  
P521 | DIGITAL | UTILITY | A/C TRIP  
[END OUTPUTS]
```

4.4 ACF Isolate LED & Button

The ACF Isolate LED indicates that the General Fire Trip List is Isolated. Pressing the ACF Isolate button toggles the isolation of this list.

References

Push Button Mode set to "TOF" Mode

Point Address: 0-5-3 ACF Isolate Button
P517 ACF Isolate Status

0-5-8 ACF Isolated LED
L257 General Fire Trip List

Equations:

3-4 General Fire Trip (ACF)

```
[INPUTS]  
STATUS ON  
L257 | LIST | DPSEUDO | GENERAL FIRE TRIP LIST (ACF ISOLATABLE)  
AND NOT STATUS SUPV  
P517 | DIGITAL | SUPERV | ACF ISOLATE  
[END INPUTS]  
[OUTPUTS]  
TRACK ON PRI=9,9  
SIG3 | SIGB | RELAY | ACF GENERAL FIRE TRIP  
HOLD ON PRI=9,9  
P521 | DIGITAL | UTILITY | A/C TRIP  
[END OUTPUTS]
```

12.3.5 Bells Isolate LED & Button

The Bells Isolate LED indicates that the External Bell is Isolated. Pressing the Bells Isolate button toggles the isolation of the Bell.

References

Push Button Mode set to "TOF" Mode

Point Address: 0-5-4 Bell Isolate Button
P518 Bell Isolate Status

0-5-9 Bells Isolated LED
L257 General Fire Trip List
SIG4 Bells Isolate NAC 2 on SPS Power Supply

Equations:

3-5 Fire Alarm Bell

```
[INPUTS]  
STATUS ON  
L257 | LIST | DPSEUDO | GENERAL FIRE TRIP LIST (ACF ISOLATABLE)  
AND NOT STATUS ON  
P518 | DIGITAL | SUPERV | BELL ISOLATE  
[END INPUTS]  
[OUTPUTS]  
TRACK ON PRI=9,9  
SIG4 | SIGB | SIGNAL | FIRE ALARM BELL  
[END OUTPUTS]
```

12.3.6 Warning System Isolate

The Warning System Isolate LED indicates that the Warning System Output is Isolated. Pressing the Warning System Isolate button toggles the isolation of the output.

SIG5 (NAC 3) on the SPS is activated when an alarm is present and the warning system is not isolated.

References

Push Button Mode set to "TOF" Mode

Point Address: 0-5-5 Warning Sys Isolate Button
P519 Warning Sys Isolate Status
0-5-10 Warning Sys Isolated LED
L257 General Fire Trip List
SIG5 Warning Sys Isolate NAC 3 on SPS Power Supply

Equations:

3-6 Warning System Trip

```
[INPUTS]
  STATUS ON
    L257 | LIST | DPSEUDO | GENERAL FIRE TRIP LIST (ACF ISOLATABLE)
  AND NOT STATUS ON
    P519 | DIGITAL | SUPERV | WARNING SYSTEM ISOLATE
[END INPUTS]
[OUTPUTS]
  TRACK ON PRI=9,9
    SIG5 | SIGB | SIGNAL | WARNING SYSTEM
[END OUTPUTS]
```

12.3.7 Clean up Equations

System Startup Initialization

This equation initializes the state of P204 to OFF during start up to prevent the alarm silenced LED from being turned on during start up.

3-18 prevent "alarm silenced" LED operating

```
[INPUTS]
  STATUS ON
    A34 | ANALOG | TIMER | SYSTEM STARTUP PULSE TIMER
[END INPUTS]
[OUTPUTS]
  HOLD OFF PRI=2,2
    P204 | DIGITAL | UTILITY | SIGNALS SILENCED
[END OUTPUTS]
```

Reset zone isolate toggle

This equation handles the toggling of the Isolate pushbuttons for each zone. A point in list 260 is set on any Isolate pushbutton being depressed so that only one action is carried out on the push of the button. This equation delays 1 second before it sets to off all the points in list L260, which contains the points P701 - P799.

Equations:

3-19 Reset zone isolate toggle

```
[INPUTS]
  STATUS ON
```

L260 | LIST | DPSEUDO | ZONE ISOLATE TOGGLES
DELAY CONSTANT 1
A258 | Analog Timer | ANALOG | TIMER | ZONE ISOLATE TOGGLES DELAY
[END INPUTS]
[OUTPUTS]
HOLD OFF PRI=9,9
L260 | LIST | DPSEUDO | ZONE ISOLATE TOGGLES
RESET TIMER
A258 | ANALOG | TIMER | ZONE ISOLATE TOGGLES DELAY
[END OUTPUTS]

12.4 Appendix D - Custom Control for Alarm Zone Facilities

An 8 Pushbutton/16 LED module is fitted for each 8 zones to display the alarm and isolate states and allow the zone to be isolated, alarm tested or fault tested.

This diagram shows the point numbers used for the push buttons and LEDs, where n = zone number. A number of pseudo digital points are used for each zone to store and control the operation.

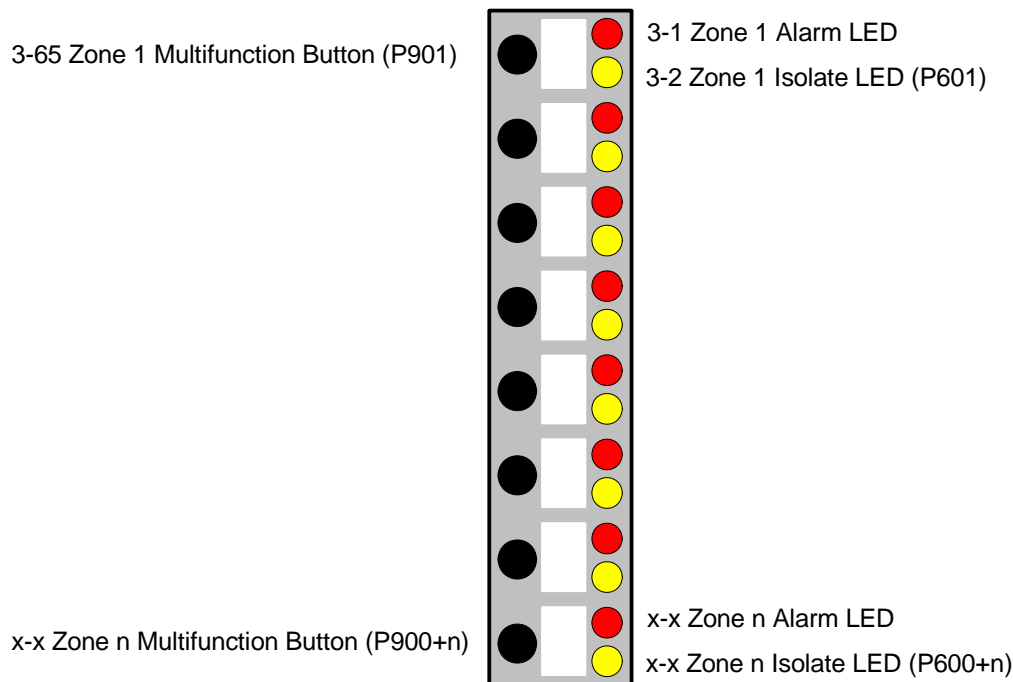

12.4.1 Digital Points used

Zone 1

- P601 – Zone 1 is Isolated
- P701 – Zone 1 Isolate Toggle
- P801 – Zone 1 is in Alarm
- P901 – Zone 1 Multifunction pushbutton
- P1001 – Zone 1 is in Alarm Test
- P1101 – Zone 1 is in Fault Test

Zone n

- P600+n – Zone n is Isolated
- P700+n – Zone n Isolate Toggle
- P800+n – Zone n is in Alarm
- P900+n – Zone n Multifunction pushbutton
- P1000+n – Zone n is in Alarm Test
- P1100+n – Zone n is in Fault Test

12.4.2 Lists

Zone 1

L261 – Zone 1 Alarm List
L262 – Zone 2 Alarm List
...
L260+n – Zone n Alarm List

12.4.3 Switches & LEDs

Zone 1

3-65 – Zone 1 Multifunction Switch
3-1 – Zone 1 Alarm LED
3-2 – Zone 1 Isolated LED

12.4.4 Zone 1 Equations

4-2 ZONE 1 Isolate Switch

```
[INPUTS]
STATUS ON
P901 | DIGITAL | UTILITY | MULTIFUNCTION SWITCH - ZONE 1
AND NOT STATUS ON
P601 | DIGITAL | SUPERV | ISOLATE ZONE 1
AND NOT STATUS ON
P701 | DIGITAL | UTILITY | ISOLATE TOGGLE ZONE 1
AND RECALL 8
[END INPUTS]
[OUTPUTS]
HOLD ON PRI=9,9
P601 | DIGITAL | SUPERV | ISOLATE ZONE 1
HOLD ON PRI=9,9
P701 | DIGITAL | UTILITY | ISOLATE TOGGLE ZONE 1
[END OUTPUTS]
```

4-3 ZONE 1 De-Isolate Switch

```
[INPUTS]
STATUS ON
P901 | DIGITAL | UTILITY | MULTIFUNCTION SWITCH - ZONE 1
AND STATUS ON
P601 | DIGITAL | SUPERV | ISOLATE ZONE 1
AND NOT STATUS ON
P701 | DIGITAL | UTILITY | ISOLATE TOGGLE ZONE 1
AND RECALL 8
[END INPUTS]
[OUTPUTS]
HOLD OFF PRI=9,9
P601 | DIGITAL | SUPERV | ISOLATE ZONE 1
HOLD ON PRI=9,9
P701 | DIGITAL | UTILITY | ISOLATE TOGGLE ZONE 1
[END OUTPUTS]
```

4-4 ZONE 1 Isolate Stops Fire

```
[INPUTS]
STATUS FIRE
L261 | LIST | MIXED | ALARM LIST ZONE 1
AND NOT STATUS ON
P601 | DIGITAL | SUPERV | ISOLATE ZONE 1
[END INPUTS]
[OUTPUTS]
TRACK ON PRI=9,9
P801 | DIGITAL | UTILITY | ALARM ZONE 1
[END OUTPUTS]
```

4-5 ZONE 1 New Alarm & LED Flash

```
[INPUTS]
  CONTINUE
  AND STATUS FALMACK
    L261 | LIST | MIXED | ALARM LIST ZONE 1
[END INPUTS]
[OUTPUTS]
  FLASH SLOW
    3-1 | LED | LED | AZF1 LED
  TRACK ON PRI=9,9
    P512 | DIGITAL | UTILITY | A ZONE ALARM LED IS FLASHING
[END OUTPUTS]
```

4-6 ZONE 1 Ack'ed Alarm & Steady LED

```
[INPUTS]
  NOT STATUS FALMACK
    L261 | LIST | MIXED | ALARM LIST ZONE 1
  OR STATUS ON
    P601 | DIGITAL | SUPERV | ISOLATE ZONE 1
  AND STATUS FIRE
    L261 | LIST | MIXED | ALARM LIST ZONE 1
[END INPUTS]
[OUTPUTS]
  FLASH ON
    3-1 | LED | LED | AZF1 LED
[END OUTPUTS]
```

4-7 ZONE 1 Alarm LED Off

```
[INPUTS]
  NOT STATUS FIRE
    L261 | LIST | MIXED | ALARM LIST ZONE 1
[END INPUTS]
[OUTPUTS]
  FLASH OFF
    3-1 | LED | LED | AZF1 LED
[END OUTPUTS]
```

12.4.5 Zone n Equations**ZONE n Isolate Switch**

```
[INPUTS]
  STATUS ON
    P900+n | DIGITAL | UTILITY | MULTIFUNCTION SWITCH - ZONE n
  AND NOT STATUS ON
    P600+n | DIGITAL | SUPERV | ISOLATE ZONE n
  AND NOT STATUS ON
    P700+n | DIGITAL | UTILITY | ISOLATE TOGGLE ZONE n
  AND RECALL 8
[END INPUTS]
[OUTPUTS]
  HOLD ON PRI=9,9
    P600+n | DIGITAL | SUPERV | ISOLATE ZONE n
  HOLD ON PRI=9,9
    P700+n | DIGITAL | UTILITY | ISOLATE TOGGLE ZONE n
[END OUTPUTS]
```

ZONE n De-Isolate Switch

```
[INPUTS]
  STATUS ON
    P900+n | DIGITAL | UTILITY | MULTIFUNCTION SWITCH - ZONE n
  AND STATUS ON
    P600+n | DIGITAL | SUPERV | ISOLATE ZONE n
  AND NOT STATUS ON
    P700+n | DIGITAL | UTILITY | ISOLATE TOGGLE ZONE n
  AND RECALL 8
[END INPUTS]
[OUTPUTS]
  HOLD OFF PRI=9,9
    P600+n | DIGITAL | SUPERV | ISOLATE ZONE n
```

HOLD ON PRI=9,9
P700+n | DIGITAL | UTILITY | ISOLATE TOGGLE ZONE n
[END OUTPUTS]

ZONE n Isolate

[INPUTS]
STATUS FIRE
L260+n | LIST | MIXED | ALARM LIST ZONE n
AND NOT STATUS ON
P600+n | DIGITAL | SUPERV | ISOLATE ZONE n
[END INPUTS]
[OUTPUTS]
TRACK ON PRI=9,9
P800+n | DIGITAL | UTILITY | ALARM ZONE n
[END OUTPUTS]

ZONE n New Alarm & LED Flash

[INPUTS]
CONTINUE
AND STATUS FALMACK
L260+n | LIST | MIXED | ALARM LIST ZONE n
[END INPUTS]
[OUTPUTS]
FLASH SLOW
X-X | LED | LED | AZFn LED (See table)
TRACK ON PRI=9,9
P512 | DIGITAL | UTILITY | A ZONE ALARM LED IS FLASHING
[END OUTPUTS]

ZONE n Ack'ed Alarm & Steady LED

[INPUTS]
NOT STATUS FALMACK
L260+n | LIST | MIXED | ALARM LIST ZONE n
OR STATUS ON
P600+n | DIGITAL | SUPERV | ISOLATE ZONE n
AND STATUS FIRE
L260+n | LIST | MIXED | ALARM LIST ZONE n
[END INPUTS]
[OUTPUTS]
FLASH ON
X-X | LED | LED | AZFn LED (See table)
[END OUTPUTS]

ZONE n Alarm LED Off

[INPUTS]
NOT STATUS FIRE
L260+n | LIST | MIXED | ALARM LIST ZONE n
[END INPUTS]
[OUTPUTS]
FLASH OFF
X-X | LED | LED | AZFn LED (See table)
[END OUTPUTS]

12.5 Appendix E - 4100-1282 AZF Switch & LED Physical Address Mapping

The following table displays the fixed mapping of zones to Display modules (using 4100-1282) with HW Ref Addresses of the Push-Buttons, the Alarm LEDs and the Isolate LEDs, and their matching Pseudo Points.

Zone #	Display Module	HW Ref. Push-Button Address	Push-Button Pseudo point Ref. Address	HW Ref. Alarm LED Address	HW Ref. Isolate LED Address	LED Pseudo point Ref. Address
1	1	3-65	P901	3-1	3-2	P601
2	1	3-66	P902	3-3	3-4	P602
3	1	3-67	P903	3-5	3-6	P603
4	1	3-68	P904	3-7	3-8	P604
5	1	3-69	P905	3-9	3-10	P605
6	1	3-70	P906	3-11	3-12	P606
7	1	3-71	P907	3-13	3-14	P607
8	1	3-72	P908	3-15	3-16	P608
9	2	3-73	P909	3-17	3-18	P609
10	2	3-74	P910	3-19	3-20	P610
11	2	3-75	P911	3-21	3-22	P611
12	2	3-76	P912	3-23	3-24	P612
13	2	3-77	P913	3-25	3-26	P613
14	2	3-78	P914	3-27	3-28	P614
15	2	3-79	P915	3-29	3-30	P615
16	2	3-80	P916	3-31	3-32	P616
17	3	3-81	P917	3-33	3-34	P617
18	3	3-82	P918	3-35	3-36	P618
19	3	3-83	P919	3-37	3-38	P619
20	3	3-84	P920	3-39	3-40	P620
21	3	3-85	P921	3-41	3-42	P621
22	3	3-86	P922	3-43	3-44	P622
23	3	3-87	P923	3-45	3-46	P623
24	3	3-88	P924	3-47	3-48	P624
25	4	3-89	P925	3-49	3-50	P625
26	4	3-90	P926	3-51	3-52	P626
27	4	3-91	P927	3-53	3-54	P627
28	4	3-92	P928	3-55	3-56	P628
29	4	3-93	P929	3-57	3-58	P629
30	4	3-94	P930	3-59	3-60	P630
31	4	3-95	P931	3-61	3-62	P631
32	4	3-96	P932	3-63	3-64	P632
33	5	4-65	P933	4-1	4-2	P633
34	5	4-66	P934	4-3	4-4	P634
35	5	4-67	P935	4-5	4-6	P635
36	5	4-68	P936	4-7	4-8	P636
37	5	4-69	P937	4-9	4-10	P637
38	5	4-70	P938	4-11	4-12	P638
39	5	4-71	P939	4-13	4-14	P639
40	5	4-72	P940	4-15	4-16	P640
41	6	4-73	P941	4-17	4-18	P641
42	6	4-74	P942	4-19	4-20	P642

43	6	4-75	P943	4-21	4-22	P643
44	6	4-76	P944	4-23	4-24	P644
45	6	4-77	P945	4-25	4-26	P645
46	6	4-78	P946	4-27	4-28	P646
47	6	4-79	P947	4-29	4-30	P647
48	6	4-80	P948	4-31	4-32	P648
49	7	4-81	P949	4-33	4-34	P649
50	7	4-82	P950	4-35	4-36	P650
51	7	4-83	P951	4-37	4-38	P651
52	7	4-84	P952	4-39	4-40	P652
53	7	4-85	P953	4-41	4-42	P653
54	7	4-86	P954	4-43	4-44	P654
55	7	4-87	P955	4-45	4-46	P655
56	7	4-88	P956	4-47	4-48	P656
57	8	4-89	P957	4-49	4-50	P657
58	8	4-90	P958	4-51	4-52	P658
59	8	4-91	P959	4-53	4-54	P659
60	8	4-92	P960	4-55	4-56	P660
61	8	4-93	P961	4-57	4-58	P661
62	8	4-94	P962	4-59	4-60	P662
63	8	4-95	P963	4-61	4-62	P663
64	8	4-96	P964	4-63	4-64	P664